

Designer Series Heaters

Packing List



Effective 7-1-18

All orders are subject to acceptance by Detroit Radiant Products Company, Warren, Michigan at prices in effect at date of shipment. All prices are F.O.B. Warren, Michigan. All State, Federal, or Municipal taxes in effect at the time of shipment or imposed at any future time on our products shall be the responsibility of the customer. We reserve the right to change specifications on our products without prior notice to the customer.



DST Series
Gas Fired Low-Intensity
Infrared Patio Heater

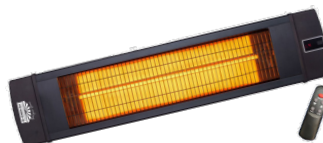

DSS Series
Short-Wave Electric Infrared
Space Heater



HL2-DS Series
Gas Fired Low-Intensity
Infrared Patio Heater

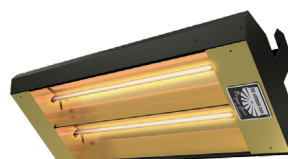

SW2 Series
Short-Wave Electric Infrared
Space Heater
(SW2 Series, coming 9-1-18)



DSCS Series
Gas Fired High-Intensity
Infrared Patio Heater

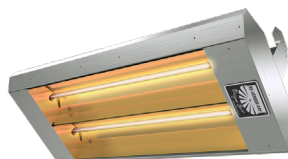

MW2 Series
Medium-Wave Electric Infrared
Space Heater
(MW2 Series, coming 9-1-18)



DGS Series
Filtered Short-Wave
Electric Infrared Heater

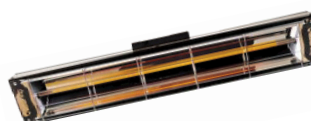

BAH Series
Medium-Wave
Electric Infrared Space Heater

Gas-Fired & Electric Designer Series Heaters

21400 Hoover Road, Warren, Michigan 48089
Phone: 586-756-0950 • Fax: 586-756-2626
www.detroitradiant.com • orders@drp-co.com

All orders are subject to acceptance by Detroit Radiant Products Company, Warren, Michigan at prices in effect at date of shipment. All prices are F.O.B. Warren, Michigan. All State, Federal, or Municipal taxes in effect at the time of shipment or imposed at any future time on our products shall be the responsibility of the customer. We reserve the right to change specifications on our products without prior notice to the customer.

Table of Contents

DST Series & Accessories	3
HL2-DS Series & Accessories	4
DSCS Series & Accessories	5
Electric Heater Product Selector	6
Electric Heater Application Chart	7
DGS Series & Accessories	8
DSS Series	9
SW2 Series	10-11
MW2 Series	12-13
SW2 & MW2 Heater Accessories	14
BAH Series & Accessories	15
Electric Components	16
Non Thermostatic Controls	16
Single-Stage & Two-Stage Controls	17
Contactor Panels	17
Electric Heater Advanced Control Options	18
Replacement Elements (DGS, SW2).	19
Contactor Panel Wiring Examples	20

The below key symbols (found within) designate the following:

SYMBOL	DESCRIPTION
†	UPS packages are charged dimensional, not physical weight.
Items in [****]	DRP product coding. For internal use only.

Shipping Weight Notation: Shipping weight is shown for each item. The per item weight will typically be less when packaging multiple items on one order.

21400 Hoover Road, Warren, Michigan 48089
 Phone: 586-756-0950 • Fax: 586-756-2626
www.detroitradiant.com • orders@drp-co.com

DST SERIES INFRARED PATIO HEATER STANDARD FEATURES



Limited Warranty: 3-5-10 (Components-Tubes-Burners)

DST SERIES STANDARD KIT CONTENTS

<p>FC-24 1/2" x 24" 304 Stainless Steel Flexible Gas Connector</p>	<p>DST-HANG Hanging Kit</p>	<p>DST-GRIP Grippler Kit for Standard Mounting</p>	<p>DST-EXH Exhaust Kit</p> <p style="font-size: small;">*Required to be installed on 80 MBH</p>
---	--	---	--

DST SERIES MODELS

Qty.	Model No.	Gas Type	BTU/h High Fire	BTU/h Low Fire	Dimensions			Mounting Heights ¹	Ship Weight ²
					Height	Length	Depth		
	DST-60N	Natural	60,000	40,000	12.75"	119.0"	17.25"	8 ft. to 13 ft.	155 lbs.
	DST-60P	Propane	60,000	50,000					
	DST-80N³	Natural	80,000	40,000	12.75"	119.0"	17.25"	9 ft. to 14 ft.	155 lbs.

¹ Typical or recommended mounting heights are provided as a guideline. Actual conditions may dictate variances from the above data.

² Truckline only.

³ Patio use only.

NOTE: Gas connection requires a 3/4" NPT adapter fitting.

DST SERIES ACCESSORIES

PART NO.	DESCRIPTION	QTY.
 [ACTB] RTVP-4	4 in. rooftop vent/intake package. Complete kit for vertical venting through the roof. Includes: RVC-4, DHC-4, FS-4, ARF-4, SC-4, VE-4, VT-4 and RTV-106 sealant. NOTE: Vent and B-vent must be ordered separately. For use with 60 MBH only.	
 [ACTB] THGH10	Optional gripper for sway bracing . 10 foot length of looped cable with a locking fastener per assembly. Working load limit of 100 lbs with a 5:1 load safety ratio.	
 [ACTB] THGH15-SS	Stainless steel gripper for sway bracing . 15 foot length of looped cable with a locking fastener per assembly. Working load limit of 100 lbs with a 5:1 load safety ratio.	
 [ACTB] 4-DSK	4 in. Duravent sidewall vent kit with all items for sidewall venting. Includes: SWD-4, WT-4, 18BV-4, DHC-4. No vent pipe material is included. 29 in. long when fully assembled. For use with 60 MBH only.	
 [ACTB] VE-4	4 in. 90° optional air intake elbow. One end is crimped.	

NOTE: Refer to the controls section of this book for control options.

HL2-DS SERIES INFRARED PATIO HEATER STANDARD FEATURES

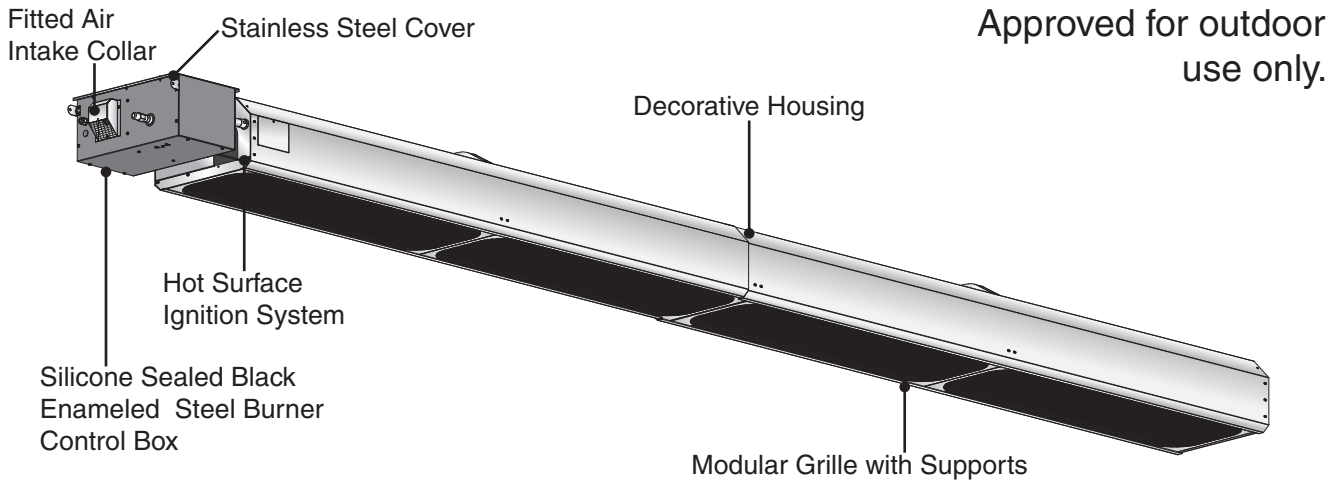

Limited Warranty: 3-5-10 (Components-Tubes-Burners)

HL2-DS SERIES KIT CONTENTS

TP-83 1/2" x 24" 304 Stainless Steel Flexible Gas Connector 	HL2DS-HANG Hanging Kit 	TP-885 Hanging Bracket (x2) 	HL2DS-ASSY Assembly Kit 	TP-33B 1/2" Shut-Off Valve (Ball Valve & Inlet Tap)
---	--------------------------------------	---	---------------------------------------	--

HL2-DS SERIES MODELS (OUTDOOR CERTIFIED ONLY)

QTY.	Model No.	Gas Type	BTU/h High Fire	BTU/h Low Fire	Overall Unit Length	Mounting Heights ¹	Ship Weight ²
	HL2-DS-30-65	Nat. or Prop.	65,000	50,000	16'-4"	9 ft. to 15 ft.	190 lbs.
	HL2-DS-30-80	Nat. or Prop.	80,000	52,000	16'-4"	9 ft. to 15 ft.	190 lbs.
	HL2-DS-30-100	Nat. or Prop.	100,000	65,000	16'-4"	9 ft. to 15 ft.	190 lbs.

¹ Typical or recommended mounting heights are provided as a guideline. Actual conditions may dictate variances from the above data.

² Truckline only.

NOTE: Gas connection requires a 3/4" NPT adapter fitting.

Shipping/Boxing:

Burner Box	(38"L x 24"W x 10"H)
Housing Box (x2)	(96"L x 22"W x 12"H)
Grille Box	(50"L x 16"W x 4"H)

HL2-DS SERIES ACCESSORIES

PART NO.	DESCRIPTION	QTY.
 [ACTB] THGH10	Optional gripper for sway bracing . 10 foot length of looped cable with a locking fastener per assembly. Working load limit of 100 lbs with a 5:1 load safety ratio.	
 [ACTB] THGH15-SS	Stainless steel gripper for sway bracing . 15 foot length of looped cable with a locking fastener per assembly. Working load limit of 100 lbs with a 5:1 load safety ratio.	

PART NO.	DESCRIPTION	QTY.
 [ACTB] DS-BKT20	21" - 32" hanging bracket kit. Kit includes components to hang 1 heater. When this option is selected the HL2DS-HANG is not included with the heater.	
 [ACTB] DS-BKT33	34" - 45" hanging bracket kit. Kit includes components to hang 1 heater. When this option is selected the HL2DS-HANG is not included with the heater.	

NOTE: See page 16 & 17 for control options.

DSC DESIGNER SERIES INFRARED PATIO HEATER STANDARD FEATURES

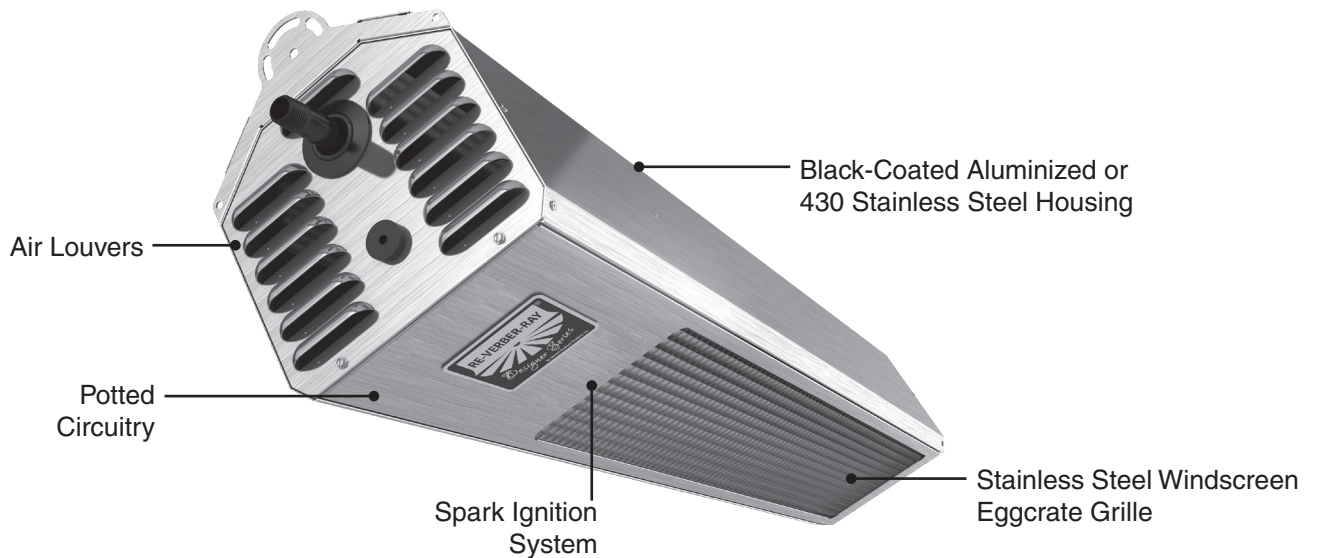

Limited Warranty: 1 year controls, 5 years burner

DSC SERIES MODELS

Model No.	Operation	Gas Type	BTU/h High Fire	BTU/h Low Fire	Dimensions			Mounting Heights ¹	Net Ship Weight ²	QTY.
					Height	Length	Width			
DSCS-31	Single- Stage	Nat. or Prop.	31,000	31,000	10.9" (to top of bracket)	48.4"	9.0"	8 ft. to 12 ft.	59 lbs.	
DSCS-34		Nat.	34,000	34,000				8.5 ft. to 13 ft.		
DSCS-31-SS		Nat. or Prop.	31,000	31,000				8 ft. to 12 ft.		
DSCS-34-SS		Nat.	34,000	34,000				8.5 ft. to 13 ft.		
DSCD-31	Dual- Stage ³	Nat. or Prop.	31,000	28,000	10.9" (to top of bracket)	48.4"	9.0"	8 ft. to 12 ft.	59 lbs.	
DSCD-34		Nat.	34,000	28,000				8.5 ft. to 13 ft.		
DSCD-31-SS		Nat. or Prop.	31,000	28,000				8 ft. to 12 ft.		
DSCD-34-SS		Nat.	34,000	28,000				8.5 ft. to 13 ft.		

¹ Typical or recommended mounting heights are provided as a guideline. Actual conditions may dictate variances from the above data.

² Shipping weight is 65 lbs. with optional mounting bracket (PH-BKT). Box dimensions 54"x17"x15". Truckline transportation for orders containing three or more units is recommended.

³ Contact factory for availability.

NOTE: Gas connection requires a 1/2" NPT adapter fitting.

DSC SERIES ACCESSORIES

PART NO.	DESCRIPTION	QTY.
 [ACDR] PH-BKT	Adjustable Mounting Bracket. Preset hardware allows the DSC Series heater to be installed at an angle between 0°-30° from horizontal. Includes black wall brackets, black connecting arms, zinc-coated nuts, bolts & washers. One set per heater. NOTE: Clearance to combustibles must be maintained at all times.	

PART NO.	DESCRIPTION	QTY.
[ACDR] PH-BKT-SS	Stainless steel PH-BKT. Includes stainless steel wall brackets, stainless steel connecting arms, and stainless steel nuts, bolts & washers. One set per heater. NOTE: Clearance to combustibles must be maintained at all times. Use with DSC-SS.	

NOTE: See page 16 & 17 for control options.

General Types

DGS Series • Filtered Short Wave Comfort+

Low wattage, commercial grade electric heater offering. Stylishly designed to provide efficient short wave directional heating with a subtle ambient red glow to enhance the overall experience and ensuring even heat distribution in residential and commercial environments. IP55 rated water protection for outdoor environments. Indoor and outdoor certified.

DSS Series • Medium Wave Comfort+

Low wattage, commercial grade electric heater offering. Produces medium wave, instant heat with the use of new technology, carbon lamps encased in a IP55 rated water protection enclosure. This heater comes with a remote control with a timer. Indoor and outdoor certified.

SW2 Series • Short Wave Industrial

High wattage, commercial grade electric heater offering. Produces short wave infrared heat energy and emits a visible ruby or white light; adding ambience to any indoor or outdoor environment. Heaters are equipped with a specially designed reflector for optimal radiant heat output and optional wall mounting brackets allow adjustment of the heating direction. Indoor and outdoor certified.

MW2 Series • Medium Wave Industrial

Medium wattage, commercial grade electric heater offering. Produces medium wave infrared heat energy with a soft visible orange glow. A great choice for romantic restaurants, outdoor patios and applications where light is not needed. Indoor and outdoor certified.

BAH Series • Medium Wave Comfort

High wattage, commercial grade electric heater offering. Quartz-Ray lamps quietly focus energy efficient infrared heat energy to the floor area, maintaining the required comfort levels for people while reducing the stratification effects. Heating elements emit a subtle red glow. Ideal for low output, low clearance to combustible areas. Indoor use only.

Estimating Heat Load

When comfort heating people, two heaters should be used to heat both sides of the individual. Heater installation shall comply with all IOPM, NEC, ANSI/NFPA-70, CEC, and local restrictions.

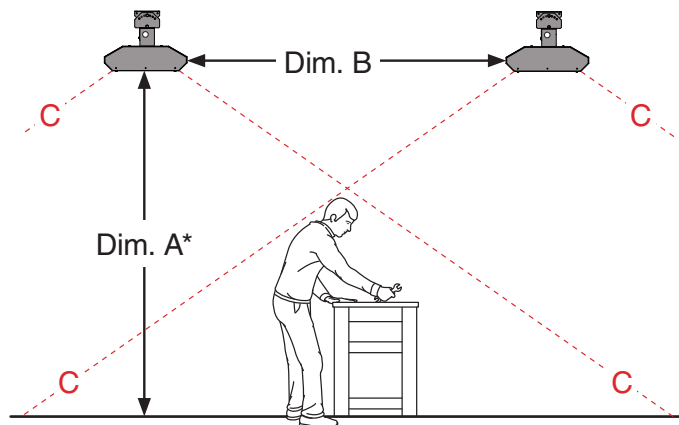

Type of Building	Watts per Square Foot	Watts per Square Meter
Insulated	10	33
Uninsulated	16	53
Outdoor Sheltered	25 to 30	80 to 100
Outdoor Unsheltered	30 to 45	100 to 148

ELECTRIC SERIES BASIC HEATING APPLICATION CHARTS (REFER TO PAGE 6)

Series	Recommended Mounting Height* [DIM A]	Recommended Distance Between Heaters [DIM B]	Approx. Coverage [C]	Approx. Watts [C]	
				per Sq. Ft.	per Sq. M
DGS-Z1-A15	7 to 9 ft. (2.1 to 2.7 m)	3 to 9 ft. (0.9 to 2.7 m)	100 sq. ft. (9.3 sq. m)	15	1.39
DGS-Z1-C20	7 to 9 ft. (2.1 to 2.7 m)	4 to 11 ft. (1.2 to 3.4 m)	100 sq. ft. (9.3 sq. m)	20	1.86
DGS-Z2-C30	8 to 10 ft. (2.4 to 3 m)	5 to 13 ft. (1.5 to 4 m)	150 sq. ft. (13.9 sq. m)	20	1.86

Series	Recommended Mounting Height* [DIM A]	Recommended Distance Between Heaters [DIM B]	Approx. Coverage [C]	Approx. Watts [C]	
				per Sq. Ft.	per Sq. M
DSS-35B1-A15	6 to 8 ft. (1.8 to 2.4 m)	3 to 9 ft. (0.9 to 2.7 m)	75 sq. ft. (7 sq. m)	20	1.86
DSS-35B1-C25	7 to 11 ft. (2.1 to 3.4 m)	1 to 11 ft. (1.2 to 3.4 m)	120 sq. ft. (11.1 sq. m)	21	1.95

Series	Lamp Qty.	Recommended Mounting Height* [DIM A]	Recommended Distance Between Heaters [DIM B]	Approx. Coverage [C]	Approx. Watts [C]	
					per Sq. Ft.	per Sq. M
SW2-24	1	8 to 10 ft. (2.4 to 3 m)	3 to 8 ft. (0.9 to 2.4 m)	400 sq. ft. (37 sq. m)	4	0.4
	2	8 to 10 ft. (2.4 to 3 m)	4 to 10 ft. (1.2 to 3 m)	400 sq. ft. (37 sq. m)	8	0.7
	3	10 to 12 ft. (3 to 3.7 m)	5 to 12 ft. (1.5 to 3.7 m)	600 sq. ft. (56 sq. m)	8	0.7
SW2-33	1	8 to 10 ft. (2.4 to 3 m)	4 to 10 ft. (1.2 to 3 m)	400 sq. ft. (37 sq. m)	6	0.6
	2	10 to 12 ft. (3 to 3.7 m)	5 to 12 ft. (1.5 to 3.7 m)	600 sq. ft. (56 sq. m)	8	0.7
	3	10 to 12 ft. (3 to 3.7 m)	6 to 14 ft. (1.8 to 4.3 m)	600 sq. ft. (56 sq. m)	12	1.1
SW2-46	1	10 to 12 ft. (3 to 3.7 m)	5 to 12 ft. (1.5 to 3.7 m)	600 sq. ft. (56 sq. m)	6	0.6
	2	12 to 14 ft. (3.7 to 4.3 m)	6 to 14 ft. (1.8 to 4.3 m)	850 sq. ft. (79 sq. m)	8 to 9	0.7 to 0.8
	3	12 to 14 ft. (3.7 to 4.3 m)	7 to 16 ft. (2.1 to 4.9m)	850 sq. ft. (79 sq. m)	12 to 13	1.1 to 1.2

Series	Lamp Qty.	Recommended Mounting Height* [DIM A]	Recommended Distance Between Heaters [DIM B]	Approx. Coverage [C]	Approx. Watts [C]	
					per Sq. Ft.	per Sq. M
MW2-24	1	7 to 9 ft. (2.1 to 2.7 m)	2 to 7 ft. (0.6 to 2.1 m)	200 sq. ft. (19 sq. m)	4	0.4
	2	7 to 9 ft. (2.1 to 2.7 m)	3 to 9 ft. (0.9 to 2.7 m)	200 sq. ft. (19 sq. m)	8	0.7
	3	8 to 10 ft. (2.4 to 3 m)	4 to 11 ft. (1.2 to 3.4 m)	300 sq. ft. (28 sq. m)	8	0.7
MW2-33	1	7 to 9 ft. (2.1 to 2.7 m)	3 to 9 ft. (0.9 to 2.7 m)	200 sq. ft. (19 sq. m)	6	0.6
	2	8 to 10 ft. (2.4 to 3 m)	4 to 11 ft. (1.2 to 3.4 m)	300 sq. ft. (28 sq. m)	8	0.7
	3	8 to 10 ft. (2.4 to 3 m)	5 to 13 ft. (1.5 to 4 m)	300 sq. ft. (28 sq. m)	11	1.0
MW2-46	1	8 to 10 ft. (2.4 to 3 m)	4 to 11 ft. (1.2 to 3.4 m)	300 sq. ft. (28 sq. m)	7 to 10	0.7 to 0.9
	2	10 to 14 ft. (3 to 4.3 m)	5 to 13 ft. (1.5 to 4 m)	500 sq. ft. (46 sq. m)	8 to 12	0.7 to 1.1
	3	10 to 15 ft. (3 to 4.6 m)	6 to 15 ft. (1.8 to 4.6 m)	500 sq. ft. (46 sq. m)	12 to 18	1.1 to 1.7

Series	Recommended Mounting Height* [DIM A]	Recommended Distance Between Heaters [DIM B]	Approx. Coverage [C]	Approx. Watts [C]	
				per Sq. Ft.	per Sq. M
BAH-18-05	6 to 8 ft. (1.8 to 2.4 m)	2 to 6 ft. (0.6 to 1.8 m)	110 sq. ft. (10 sq. m)	5	0.5
BAH-25-10	7 to 9 ft. (2.1 to 2.7 m)	3 to 9 ft. (0.9 to 2.7 m)	144 sq. ft. (13 sq. m)	7	0.7
BAH-35-17	7 to 10 ft. (2.1 to 3 m)	3 to 10 ft. (0.9 to 3 m)	163 sq. ft. (15 sq. m)	11	1.0
BAH-45-25	8 to 10 ft. (2.4 to 3 m)	4 to 11 ft. (1.2 to 3.4 m)	182 sq. ft. (17 sq. m)	14	1.3
BAH-60-30	8 to 12 ft. (2.4 to 3.7 m)	4 to 11 ft. (1.2 to 3.4 m)	225 sq. ft. (21 sq. m)	13	1.2
BAH-60-40	8 to 14 ft. (2.4 to 4.3 m)	5 to 13 ft. (1.5 to 4 m)	272 sq. ft. (25 sq. m)	15	1.4

*Clearance to combustibles published in the DGS, DSS, SW, MW, and BAH Series Installation, Operation, Maintenance and Parts Manuals and on safety labels must be maintained at all times. Factory recommended mounting heights are listed as a guideline. If infrared heaters are mounted too low or too high, they may result in discomfort or lack of heat.

Disclaimer:

It is important to note that the effectiveness of the heater may be diminished in environments with wind velocities above 5 MPH.



DGS Series

Filtered Short-Wave Comfort



The DGS Series has proven to be an excellent option to electric heating that values aesthetics with its modern design and high-end quality. This heater features a custom designed reflector that focuses the desired heat pattern to your space. Thanks to its extruded aluminum body, the DGS Series is easily able to withstand harsh outdoor conditions (IP55 rated) or provide a stylish look to your indoor space. Choose this product to give a sleek look to your outdoor residential patio or restaurant to extend the season.



DGS-Z1-C20 shown



DGS-Z2-C30 shown

DGS Series Models

1,500 to 3,000 Watts

Limited Warranty: 1-year on DGS Series heater components.

NOTE: Lamp is included with heater purchase.

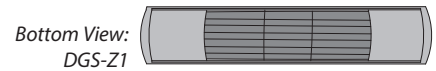

MODEL NUMBER	VOLTS	WATTS	BTU'S	AMPS	LAMP PART #	DIMENSIONS			WEIGHT	QTY.
						Length	Width	Height		
DGS-Z1-A15	120	1,500	5,118	12.5	EL-15A	21.06" (536 mm)	4.61" (117 mm)	4.84" (123 mm)	5.7 lbs (2.6 kg)	
DGS-Z1-C20	230	2,000	6,824	8.7	EL-20C	21.06" (536 mm)	4.61" (117 mm)	4.84" (123 mm)	5.7 lbs (2.6 kg)	
DGS-Z2-C30	230	3,000	10,236	13.0	EL-15C	36.75" (934 mm)	4.61" (117 mm)	4.84" (123 mm)	9.7 lbs (4.4 kg)	

All models have a bronze color finish with gold-filtered, red lamps.

See pages 16-18 for control options. See page 19 for replacement lamp elements.

PART NO.	DESCRIPTION	QTY.
[ACEL] DGS-BKT	Coming Soon. Optional extended hanging bracket for wall mount or angle mount installations.	



DSS Series

Medium-Wave Comfort



Outdoor approved DSS Series heaters produce medium-wave, instant heat with the use of new technology, carbon lamps encased in a IP55 rated, compact, slim, black enclosure. This heater offers a remote control with timer functionality and four power settings. Operational benefits include a highly efficient energy transfer, even heat distribution, and intense heat output.

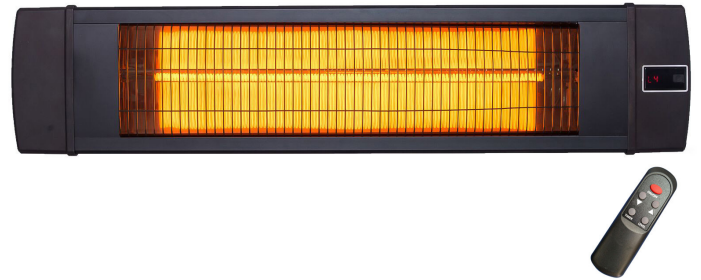

DSS Series Models

1,500 to 2,500 Watts

Limited Warranty: 1-year on DSS Series heater components.

NOTE: Lamp is included with heater purchase.

MODEL NUMBER	VOLTS	WATTS	BTU'S	AMPS	DIMENSIONS			WEIGHT	QTY.
					Length	Width	Height		
DSS-35B1-A15	120	1,500	5,118	12.5	34.65" (880 mm)	7.48" (190 mm)	3.15" (80 mm)	6.6 lbs (3 kg)	
DSS-35B1-C25	230	2,500	8,530	10.87	34.65" (880 mm)	7.48" (190 mm)	3.15" (80 mm)	6.6 lbs (3 kg)	

All models have a black color finish with carbon lamps.

See pages 16-18 for control options. See page 19 for replacement lamp elements.



SW2 Series



Short Wave Industrial

SW2 will replace the SW effective 9/1/18.
Any orders placed prior will be SW models.

SW2 Series heaters are unique in their ability to produce both infrared heat and visible light energy. The source of this energy comes from short wave electric lamps encased in an aesthetically pleasing enclosure. Available in an assortment of sizes, casings and elements, this heater offers both choices and solutions for your application.

Operational benefits include a highly efficient energy transfer, lower mounting heights, heat energy, light energy, and certification for both indoor or outdoor use.

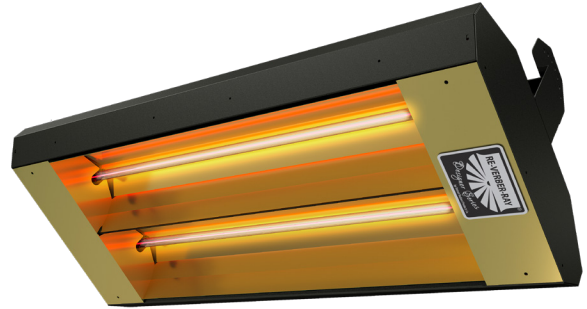

33B2-B25R shown

See page 12 for applicable accessories.

SW2 Series Single Lamp Models

1,600 to 3,800 Watts

Limited Warranty: 1-year on SW2 Series heater components.

NOTE: Lamp is included with heater purchase.

Bottom View:
SW2 Series single lamp

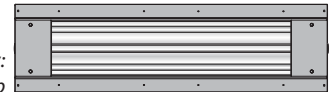

	MODEL NUMBER		VOLTS	WATTS	BTU/h	AMPS	LAMP PART #	SHIP WEIGHT	QTY.	
	BLACK POWDER COAT HOUSING	STAINLESS STEEL HOUSING							BLACK	STAINLESS STEEL
CLEAR (WHITE) LAMP	SW2-24B1-A16W	SW2-24S1-A16W	120	1,600	5,459	13.3	EL-070A	15 lbs (6.8 kg)		
	SW2-24B1-B16W	SW2-24S1-B16W	208	1,600	5,459	7.69	EL-071A	15 lbs (6.8 kg)		
	SW2-24B1-C16W	SW2-24S1-C16W	240	1,600	5,459	6.67	EL-073A	15 lbs (6.8 kg)		
	SW2-24B1-G16W	SW2-24S1-G16W	480	1,600	5,459	3.33	EL-075A	15 lbs (6.8 kg)		
	SW2-33B1-B25W	SW2-33S1-B25W	208	2,500	8,530	12.02	EL-072A	19 lbs (8.6 kg)		
	SW2-33B1-C25W	SW2-33S1-C25W	240	2,500	8,530	10.42	EL-074A	19 lbs (8.6 kg)		
	SW2-33B1-G25W	SW2-33S1-G25W	480	2,500	8,530	5.21	EL-076A	19 lbs (8.6 kg)		
	SW2-46B1-G36W ¹	SW2-46S1-G36W ¹	480	3,650	12,454	7.60	EL-077A	24 lbs (10.8 kg)		
SW2-46B1-H38W ¹	SW2-46S1-H38W ¹	575	3,800	12,966	6.61	EL-078A	24 lbs (10.8 kg)			
REDUCED GLARE (RUBY) LAMP	SW2-24B1-A16R	SW2-24S1-A16R	120	1,600	5,459	13.3	EL-080A	15 lbs (6.8 kg)		
	SW2-24B1-B16R	SW2-24S1-B16R	208	1,600	5,459	7.69	EL-081A	15 lbs (6.8 kg)		
	SW2-24B1-C16R	SW2-24S1-C16R	240	1,600	5,459	6.67	EL-083A	15 lbs (6.8 kg)		
	SW2-24B1-G16R	SW2-24S1-G16R	480	1,600	5,459	3.33	EL-085A	15 lbs (6.8 kg)		
	SW2-33B1-B25R	SW2-33S1-B25R	208	2,500	8,530	12.02	EL-082A	19 lbs (8.6 kg)		
	SW2-33B1-C25R	SW2-33S1-C25R	240	2,500	8,530	10.42	EL-084A	19 lbs (8.6 kg)		
	SW2-33B1-G25R	SW2-33S1-G25R	480	2,500	8,530	5.21	EL-086A	19 lbs (8.6 kg)		
	SW2-46B1-G36R ¹	SW2-46S1-G36R ¹	480	3,650	12,454	7.60	EL-087A	24 lbs (10.8 kg)		
SW2-46B1-H38R ¹	SW2-46S1-H38R ¹	575	3,800	12,966	6.61	EL-088A	24 lbs (10.8 kg)			

¹Not available to ship via UPS. Truckline only.

See pages 14, 16-18 for applicable accessories. See page 19 for replacement lamp elements.

SW2 Series Dual Lamp Models

3,200 to 7,600 Watts

Limited Warranty: 1-year on SW2 Series heater components.

NOTE: Lamp is included with heater purchase

Bottom View:
SW2 Series dual lamp

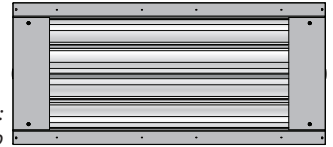

	MODEL NUMBER		VOLTS	WATTS	BTU/h	AMPS	LAMP PART # (INCL)	SHIP WEIGHT	QTY.	
	BLACK POWDER COAT HOUSING	STAINLESS STEEL HOUSING							BLACK	STAINLESS STEEL
CLEAR (WHITE) LAMP	SW2-24B2-B16W	SW2-24S2-B16W	208	3,200	10,919	15.38	EL-071A	20 lbs (9.1 kg)		
	SW2-24B2-C16W	SW2-24S2-C16W	240	3,200	10,919	13.33	EL-073A	20 lbs (9.1 kg)		
	SW2-24B2-G16W	SW2-24S2-G16W	480	3,200	10,919	6.67	EL-075A	20 lbs (9.1 kg)		
	SW2-33B2-B25W	SW2-33S2-B25W	208	5,000	17,061	24.04	EL-072A	26 lbs (11.8 kg)		
	SW2-33B2-C25W	SW2-33S2-C25W	240	5,000	17,061	20.83	EL-074A	26 lbs (11.8 kg)		
	SW2-33B2-G25W	SW2-33S2-G25W	480	5,000	17,061	10.42	EL-076A	26 lbs (11.8 kg)		
	SW2-46B2-G36W ¹	SW2-46S2-G36W ¹	480	7,300	24,909	15.21	EL-077A	32 lbs (14.5 kg)		
	SW2-46B2-H38W ¹	SW2-46S2-H38W ¹	575	7,600	25,932	13.22	EL-078A	32 lbs (14.5 kg)		
REDUCED GLARE (RUBY) LAMP	SW2-24B2-B16R	SW2-24S2-B16R	208	3,200	10,919	15.38	EL-081A	20 lbs (9.1 kg)		
	SW2-24B2-C16R	SW2-24S2-C16R	240	3,200	10,919	13.33	EL-083A	20 lbs (9.1 kg)		
	SW2-24B2-G16R	SW2-24S2-G16R	480	3,200	10,919	6.67	EL-085A	20 lbs (9.1 kg)		
	SW2-33B2-B25R	SW2-33S2-B25R	208	5,000	17,061	24.04	EL-082A	26 lbs (11.8 kg)		
	SW2-33B2-C25R	SW2-33S2-C25R	240	5,000	17,061	20.83	EL-084A	26 lbs (11.8 kg)		
	SW2-33B2-G25R	SW2-33S2-G25R	480	5,000	17,061	10.42	EL-086A	26 lbs (11.8 kg)		
	SW2-46B2-G36R ¹	SW2-46S2-G36R ¹	480	7,300	24,909	15.21	EL-087A	32 lbs (14.5 kg)		
	SW2-46B2-H38R ¹	SW2-46S2-H38R ¹	575	7,600	25,932	13.22	EL-088A	32 lbs (14.5 kg)		

¹Not available to ship via UPS. Truckline only.

See pages 14, 16-18 for applicable accessories. See page 19 for replacement lamp elements.

SW2 Series Triple Lamp Models

4,800 to 11,400 Watts

Limited Warranty: 1-year on SW2 Series heater components.

NOTE: Lamp is included with heater purchase.

Bottom View:
SW2 Series triple lamp

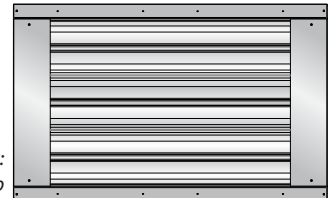

	MODEL NUMBER		VOLTS	WATTS	BTU/h	AMPS	LAMP PART #	SHIP WEIGHT	QTY.	
	BLACK POWDER COAT HOUSING	STAINLESS STEEL HOUSING							BLACK	STAINLESS STEEL
CLEAR (WHITE) LAMP	SW2-24B3-B16W	SW2-24S3-B16W	208	4,800	16,378	23.08	EL-071A	25 lbs (11.4 kg)		
	SW2-24B3-C16W	SW2-24S3-C16W	240	4,800	16,378	20.00	EL-073A	25 lbs (11.4 kg)		
	SW2-24B3-G16W	SW2-24S3-G16W	480	4,800	16,378	10.00	EL-075A	25 lbs (11.4 kg)		
	SW2-33B3-G25W ¹	SW2-33S3-G25W ¹	480	7,500	24,909	15.63	EL-076A	32 lbs (14.5 kg)		
	SW2-46B3-G36W ¹	SW2-46S3-G36W ¹	480	10,950	37,636	22.81	EL-077A	40 lbs (18.1 kg)		
	SW2-46B3-H38W ¹	SW2-46S3-H38W ¹	575	11,400	38,898	19.83	EL-078A	40 lbs (18.1 kg)		
REDUCED GLARE (RUBY) LAMP	SW2-24B3-B16R	SW2-24S3-B16R	208	4,800	16,378	23.08	EL-081A	25 lbs (11.4 kg)		
	SW2-24B3-C16R	SW2-24S3-C16R	240	4,800	16,378	20.00	EL-083A	25 lbs (11.4 kg)		
	SW2-24B3-G16R	SW2-24S3-G16R	480	4,800	16,378	10.00	EL-085A	25 lbs (11.4 kg)		
	SW2-33B3-G25R ¹	SW2-33S3-G25R ¹	480	7,500	24,909	15.63	EL-086A	32 lbs (14.5 kg)		
	SW2-46B3-G36R ¹	SW2-46S3-G36R ¹	480	10,950	37,636	22.81	EL-087A	40 lbs (18.1 kg)		
	SW2-46B3-H38R ¹	SW2-46S3-H38R ¹	575	11,400	38,898	19.83	EL-088A	40 lbs (18.1 kg)		

¹Not available to ship via UPS. Truckline only.

See pages 14, 16-18 for applicable accessories. See page 19 for replacement lamp elements.



MW2 Series



Medium Wave Industrial

MW2 will replace the MW effective 9/1/18.
Any orders placed prior will be MW models.

MW2 Series heaters are unique in their ability to produce infrared heat. The source of this energy comes from medium wave electric lamps encased in an aesthetically pleasing enclosure. Available in an assortment of sizes and casings, this heater offers both choices and solutions for your application. Operational benefits include a highly efficient energy transfer, lower mounting heights, and heat energy.



33S2-A12 shown

See page 12 for applicable accessories.

MW2 Series Single Lamp Models

750 to 3,000 Watts

Limited Warranty: 1-year on MW2 Series heater components.

NOTE: Lamp is included with heater purchase.

Bottom View:
MW2 Series single lamp

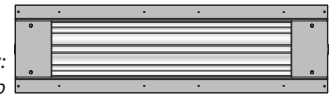

MODEL NUMBER		VOLTS	WATTS	BTU'S	AMPS	LAMP PART NO.	SHIP WEIGHT	QTY.	
BLACK POWDER COAT HOUSING	STAINLESS STEEL HOUSING							BLACK	STAINLESS STEEL
MW2-24B1-A07	MW2-24S1-A07	120	750	2,559	6.25	EL-1070	15 lbs (6.8 kg)		
MW2-24B1-B07	MW2-24S1-B07	208	750	2,559	3.6	EL-1072	15 lbs (6.8 kg)		
MW2-24B1-C07	MW2-24S1-C07	240	750	2,559	3.1	EL-1074	15 lbs (6.8 kg)		
MW2-33B1-A12	MW2-33S1-A12	120	1,250	4,265	10.4	EL-1078	19 lbs (8.6 kg)		
MW2-33B1-B12	MW2-33S1-B12	208	1,250	4,265	6.0	EL-1080	19 lbs (8.6 kg)		
MW2-33B1-C12	MW2-33S1-C12	240	1,250	4,265	5.2	EL-1082	19 lbs (8.6 kg)		
MW2-46B1-A20 ¹	MW2-46S1-A20 ¹	120	2,000	6,824	16.6	EL-1086	24 lbs (10.8 kg)		
MW2-46B1-B20 ¹	MW2-46S1-B20 ¹	208	2,000	6,824	9.6	EL-1088	24 lbs (10.8 kg)		
MW2-46B1-C20 ¹	MW2-46S1-C20 ¹	240	2,000	6,824	8.3	EL-1090	24 lbs (10.8 kg)		
MW2-46B1-G20 ¹	MW2-46S1-G20 ¹	480	2,000	6,824	4.2	EL-1092	24 lbs (10.8 kg)		
MW2-46B1-H30 ¹	MW2-46S1-H30 ¹	575	3,000	10,236	5.2	EL-1094	24 lbs (10.8 kg)		

¹Not available to ship via UPS. Truckline only.

See pages 14, 16-18 for applicable accessories. See page 20 for replacement lamp elements.

MW2 Series Dual Lamp Models

1,500 to 6,000 Watts

Limited Warranty: 1-year on MW2 Series heater components.

NOTE: Lamp is included with heater purchase.

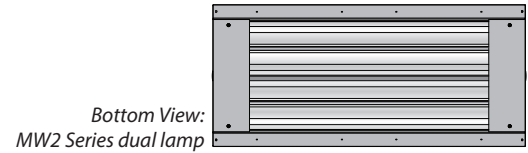

MODEL NUMBER		VOLTS	WATTS	BTU'S	AMPS	LAMP PART NO.	SHIP WEIGHT	QTY.	
BLACK POWDER COAT HOUSING	STAINLESS STEEL HOUSING							BLACK	STAINLESS STEEL
MW2-24B2-A07	MW2-24S2-A07	120	1,500	5,118	12.5	EL-1070	20 lbs (9.1 kg)		
MW2-24B2-B07	MW2-24S2-B07	208	1,500	5,118	7.2	EL-1072	20 lbs (9.1 kg)		
MW2-24B2-C07	MW2-24S2-C07	240	1,500	5,118	6.2	EL-1074	20 lbs (9.1 kg)		
MW2-33B2-A12	MW2-33S2-A12	120	2,500	8,530	20.8	EL-1078	26 lbs (11.8 kg)		
MW2-33B2-B12	MW2-33S2-B12	208	2,500	8,530	12.0	EL-1080	26 lbs (11.8 kg)		
MW2-33B2-C12	MW2-33S2-C12	240	2,500	8,530	10.4	EL-1082	26 lbs (11.8 kg)		
MW2-46B2-B20 ¹	MW2-46S2-B20 ¹	208	4,000	13,649	19.2	EL-1088	32 lbs (14.5 kg)		
MW2-46B2-C20 ¹	MW2-46S2-C20 ¹	240	4,000	13,649	16.6	EL-1090	32 lbs (14.5 kg)		
MW2-46B2-G20 ¹	MW2-46S2-G20 ¹	480	4,000	13,649	8.3	EL-1092	32 lbs (14.5 kg)		
MW2-46B2-H30 ¹	MW2-46S2-H30 ¹	575	6,000	20,473	10.4	EL-1094	32 lbs (14.5 kg)		

¹Not available to ship via UPS. Truckline only.

See pages 14, 16-18 for applicable accessories. See page 20 for replacement lamp elements.

MW2 Series Triple Lamp Models

2,250 to 9,000 Watts

Limited Warranty: 1-year on MW2 Series heater components.

NOTE: Lamp is included with heater purchase.

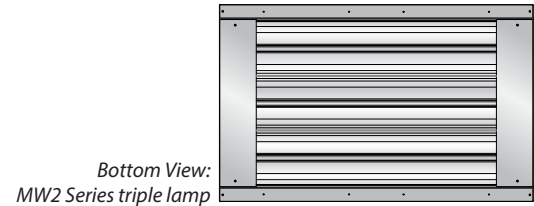

MODEL NUMBER		VOLTS	WATTS	BTU'S	AMPS	LAMP PART NO.	SHIP WEIGHT	QTY.	
BLACK POWDER COAT HOUSING	STAINLESS STEEL HOUSING							BLACK	STAINLESS STEEL
MW2-24B3-A07	MW2-24S3-A07	120	2,250	7,677	18.7	EL-1070	25 lbs (11.4 kg)		
MW2-24B3-B07	MW2-24S3-B07	208	2,250	7,677	10.8	EL-1072	25 lbs (11.4 kg)		
MW2-24B3-C07	MW2-24S3-C07	240	2,250	7,677	9.3	EL-1074	25 lbs (11.4 kg)		
MW2-33B3-A12 ¹	MW2-33S3-A12 ¹	120	3,750	12,796	27.0	EL-1078	32 lbs (14.5 kg)		
MW2-33B3-B12 ¹	MW2-33S3-B12 ¹	208	3,750	12,796	15.6	EL-1080	32 lbs (14.5 kg)		
MW2-33B3-C12 ¹	MW2-33S3-C12 ¹	240	3,750	12,796	13.5	EL-1082	32 lbs (14.5 kg)		
MW2-46B3-B20 ¹	MW2-46S3-B20 ¹	208	6,000	20,473	28.8	EL-1088	40 lbs (18.1 kg)		
MW2-46B3-C20 ¹	MW2-46S3-C20 ¹	240	6,000	20,473	25.0	EL-1090	40 lbs (18.1 kg)		
MW2-46B3-G20 ¹	MW2-46S3-G20 ¹	480	6,000	20,473	12.5	EL-1092	40 lbs (18.1 kg)		
MW2-46B3-H30 ¹	MW2-46S3-H30 ¹	575	9,000	30,709	15.6	EL-1094	40 lbs (18.1 kg)		

¹Not available to ship via UPS. Truckline only.

See pages 14, 16-18 for applicable accessories. See page 20 for replacement lamp elements.

SW2 & MW2 SERIES ELECTRIC HEATER ACCESSORIES

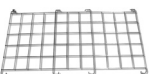
PART NO.	DESCRIPTION	QTY.
 [ACSW] EL-WMB	SW2 & MW2 wall mounting brackets. Designed to support in a sidewall mounting application. 11 ga. stainless steel construction. Dimensional data available upon request. One set per heater.	
	SW2 & MW2 Series wire guard protects lamps and reflective surfaces from objects and debris. Stainless Steel .125 ga. wire mesh. Each part fits a specific model. Dimensional data available upon request.	
[ACSW] EL-1WG24	SW2 & MW2 Series wire guard fits 24" single element.	
[ACSW] EL-1WG33	SW2 & MW2 Series wire guard fits 33" single element.	

PART NO.	DESCRIPTION	QTY.
[ACSW] EL-1WG46	SW2 & MW2 Series wire guard fits 46" single element.	
[ACSW] EL-2WG24	SW2 & MW2 Series wire guard fits 24" double element.	
[ACSW] EL-2WG33	SW2 & MW2 Series wire guard fits 33" double element.	
[ACSW] EL-2WG46	SW2 & MW2 Series wire guard fits 46" double element.	
[ACSW] EL-3WG24	SW2 & MW2 Series wire guard fits 24" triple element.	
[ACSW] EL-3WG33	SW2 & MW2 Series wire guard fits 33" triple element.	
[ACSW] EL-3WG46	SW2 & MW2 Series wire guard fits 46" triple element.	

PART NO.	DESCRIPTION	QTY.
	Recessed mounting frame fits around and supports SW2 or MW2 Series heater for recessed mount applications. Black Finish construction. Each part fits a specific model. Dimensional data available upon request.	
[ACSW] EL-1FR24	SW2 & MW2 Series recessed mount fits 24" single element.	
[ACSW] EL-1FR33	SW2 & MW2 Series recessed mount fits 33" single element.	
[ACSW] EL-1FR46	SW2 & MW2 Series recessed mount fits 46" single element.	
[ACSW] EL-2FR24	SW2 & MW2 Series recessed mount fits 24" double element.	
[ACSW] EL-2FR33	SW2 & MW2 Series recessed mount fits 33" double element.	
[ACSW] EL-2FR46	SW2 & MW2 Series recessed mount fits 46" double element.	
[ACSW] EL-3FR24	SW2 & MW2 Series recessed mount fits 24" triple element.	
[ACSW] EL-3FR33	SW2 & MW2 Series recessed mount fits 33" triple element.	
[ACSW] EL-3FR46	SW2 & MW2 Series recessed mount fits 46" triple element.	

PART NO.	DESCRIPTION	QTY.
	Recessed mounting frame fits around and supports SW or MW Series heater for recessed mount applications. Stainless steel construction. Each part fits a specific model. Dimensional data available upon request.	
[ACSW] EL-1FR24-SS	SW2 & MW2 Series recessed mount fits 24" single element.	
[ACSW] EL-1FR33-SS	SW2 & MW2 Series recessed mount fits 33" single element.	
[ACSW] EL-1FR46-SS	SW2 & MW2 Series recessed mount fits 46" single element.	
[ACSW] EL-2FR24-SS	SW2 & MW2 Series recessed mount fits 24" double element.	
[ACSW] EL-2FR33-SS	SW2 & MW2 Series recessed mount fits 33" double element.	
[ACSW] EL-2FR46-SS	SW2 & MW2 Series recessed mount fits 46" double element.	
[ACSW] EL-3FR24-SS	SW2 & MW2 Series recessed mount fits 24" triple element.	
[ACSW] EL-3FR33-SS	SW2 & MW2 Series recessed mount fits 33" triple element.	
[ACSW] EL-3FR46-SS	SW2 & MW2 Series recessed mount fits 46" triple element.	

BAH Series

Medium Wave Comfort



Electric infrared heaters are the cleanest method of heating, taking nothing from the air and adding nothing to the air. They produce heat by running an electric current through a high resistance element. The BAH Series is ideal for low output, low clearance to combustible areas and in applications where gas and/or ventilation is not available or impractical.



BAH-35A-17 shown

BAH Series Models

500 to 4,000 Watts

Limited Warranty: 1-year on BAH Series heater components.

MODEL NO.	VOLTS	kW	WATTS	AMP	BTU/h	LENGTH	WIDTH	HEIGHT	SHIP WEIGHT	QTY.
BAH-18-A-05	120	0.5	500	4.2	1,700	18" (457 mm)	6.75" (172 mm)	6.4" (163 mm)	8 lbs (3.6 kg)	
BAH-25-A-10	120	1.0	1,000	8.3	3,400	25" (635 mm)	6.75" (172 mm)	6.4" (163 mm)	10 lbs (4.5 kg)	
BAH-25-B-10	208	1.0	1,000	4.8	3,400	25" (635 mm)	6.75" (172 mm)	6.4" (163 mm)	10 lbs (4.5 kg)	
BAH-25-C-10	240	1.0	1,000	4.2	3,400	25" (635 mm)	6.75" (172 mm)	6.4" (163 mm)	10 lbs (4.5 kg)	
BAH-35-A-17 ²	120	1.7	1,750	14.0	5,900	35" (889 mm)	6.75" (172 mm)	6.4" (163 mm)	13 lbs (5.9 kg)	
BAH-35-B-17 ²	208	1.7	1,750	8.3	5,900	35" (889 mm)	6.75" (172 mm)	6.4" (163 mm)	13 lbs (5.9 kg)	
BAH-35-C-17 ²	240	1.7	1,750	7.0	5,900	35" (889 mm)	6.75" (172 mm)	6.4" (163 mm)	13 lbs (5.9 kg)	
BAH-45-B-25 ²	208	2.5	2,500	12.0	8,500	45" (1143 mm)	6.75" (172 mm)	6.4" (163 mm)	16 lbs (7.3 kg)	
BAH-45-C-25 ²	240	2.5	2,500	10.0	8,500	45" (1143 mm)	6.75" (172 mm)	6.4" (163 mm)	16 lbs (7.3 kg)	
BAH-60-B-30 ^{1,2}	208	3.0	3,000	14.0	10,200	60" (1524 mm)	6.75" (172 mm)	6.4" (163 mm)	20 lbs (9.1 kg)	
BAH-60-C-30 ^{1,2}	240	3.0	3,000	12.0	10,200	60" (1524 mm)	6.75" (172 mm)	6.4" (163 mm)	20 lbs (9.1 kg)	
BAH-60-C-40 ^{1,2}	240	4.0	4,000	16.5	13,500	60" (1524 mm)	6.75" (172 mm)	6.4" (163 mm)	20 lbs (9.1 kg)	
BAH-60-D-40 ¹	575	4.0	4,000	7.0	13,500	60" (1524 mm)	6.75" (172 mm)	6.4" (163 mm)	20 lbs (9.1 kg)	

BAH Series heaters are NOT for home or recreational use. DO NOT USE in the home, mobile home, RV's, campers, tents, etc. See pages 16-18 for control options. See page 20 for replacement lamp elements.

¹Not available to ship via UPS. Truckline only.



²Heater is stocked and will ship from Detroit Radiant Products Company. Non-stocked heaters may ship from Brantford, Ontario. Subject to 6-8 week lead time.

BAH Series Electric Heater Accessories

PART NO.	DESCRIPTION	QTY.
 [ACEL] MB-1	BAH Mounting Bracket. Used for wall and ceiling mounting. Total range of adjustment is 180°. Sold in pairs. Not included with heater. NOTE: Clearance to combustibles must be maintained.	



ELECTRICAL COMPONENTS

PART NO.	DESCRIPTION	QTY.
[ACCM] TR-96VA	96 VA transformer. Connect up to five (5) DSC Series heaters per transformer.	
 [ACTB] ERK	The External Relay Kit accessory can be used on HL3, HL2, DX3L, LS3 & LD3 models that require multiple heaters on one thermostat. This can mount on or near the heater. One ERK is needed per heater. Used in standard environments. An external transformer (eg. 4000-01V) is needed to power the control.	

PART NO.	DESCRIPTION	QTY.
 [ACCM] 4000-01V	40 VA transformer 120-24V. AC primary & secondary. Mounted on 4 x 4 base plate. Connect up to two (2) DSC Series heaters per transformer.	
 [ACTB] ERK-HE	Similar to ERK but utilizes a rugged NEMA 6P rated enclosure for use in wet and corrosive environments. An external transformer (eg. 4000-01V) is needed to power the control.	



NON THERMOSTATIC CONTROLS



PART NO.	DESCRIPTION	QTY.
 [ACCP] TH-DSSS1	<u>Single-zone, single-stage</u> , low voltage infrared patio heater controller with illuminated control knob. Standard with faceplate and heavy duty junction box. Modern aesthetic for use in high-end outdoor or indoor applications.	
 [ACCP] TH-DSSS2	<u>Two-zone, single-stage</u> , low voltage infrared patio heater controller with two illuminated control knobs. Standard with faceplate and heavy duty junction box. Modern aesthetic for use in high-end outdoor or indoor applications.	
	Paragon Timer. Manually activated time control with white wall plate and knob. 120V - 20amp @ 120 Volts or 240 / 277 Volts - 10 amps. Also compatible with 24V systems.	
[ACCP] SWPD60	60 minute twist timer with 5 minute increments.	
[ACCP] SWPD-4H	4 hour twist timer.	

PART NO.	DESCRIPTION	QTY.
 [ACCP] TH-DSTS1	<u>Single-zone, two-stage</u> , low voltage infrared patio heater controller with illuminated control knob. Standard with faceplate and heavy duty junction box. Modern aesthetic for use in high-end outdoor or indoor applications.	
 [ACCP] TH-DSTS2	<u>Two-zone, two-stage</u> , low voltage infrared patio heater controller with two illuminated control knobs. Standard with faceplate and heavy duty junction box. Modern aesthetic for use in high-end outdoor or indoor applications.	
 [ACCP] WEP-TS	Weatherproof enclosure package with 4-hour timer and on-off control. Ideal for use in outdoor heating applications where timer control is desired. Package for two-stage scenarios. Can operate up to 120V-20 amp. Can also be used for 24V switching. Field assembly and wiring required.	

NOTE: Refer to heater manual on field wiring to determine if the use of a relay and external transformer will be required (eg. 4000-01V).

SINGLE-STAGE & TWO-STAGE CONTROLS

PART NO.	DESCRIPTION	QTY.
 [ACCP] TH-P721	LuxPro single-stage or two-stage programmable 7 day, 5/2 day, or non-programmable thermostat. 45°-90°F range. 1.5 Amps at 24VAC (15 heaters with HLRP and 4000-01V). Features include 2 or 4 selectable periods per day, °C/°F display, and keypad lock.	
 [ACCP] TH-ET5	Columbus Electric single-stage thermostat. 35°-75°F range. White plastic cover, 120-277 VAC, 22.0 amps. May be used to switch either 24V, 120V or 220V. Consult amp rating of unit for proper sizing.	

PART NO.	DESCRIPTION	QTY.
 [ACEL] TH-1A66	Use with DGS, SW, MW, and BAH Series. Heater thermostat with 40-85°F range. Double line break with positive off. For use on heaters up to 277V. 22 amps at 120 or 240 VAC non-inductive; 18 amps at 277 VAC non-inductive. Common thermostat when amperage permits. Do not use with contactor panels.	
 [ACCP] TH-115	Single-Stage thermostat with rain tight enclosure and 40° to 100°F range. Rugged weatherproof control for use in agricultural, industrial and commercial environments with heavy moisture atmospheres. 16.0 FLA, 25.0 amps resistive at 120V. NEMA 4X rated. Can be used with 24-277 VAC. Consult amp rating of unit for proper sizing.	

CONTACTOR PANELS (FOR ON/OFF CONTROLS ONLY)

NOTE: DGS, SW2, and MW2 Series heaters are not manufactured with a control device. Control devices shall be field supplied and must meet local and/or national codes. Suitable control configurations include switching devices and/or integrated relay panels properly rated for the heater's voltage, amperage and installation requirements. Contact the factory for further technical assistance.

PART NO.	DESCRIPTION	QTY.
 Appearance may differ. [ACCP] CE-40-24	Contactor with enclosures. Ideal switching device for use with other control equipment. NEMA 1 Enclosures. Magnetic contactor with Load rating up to 600V Max., 3-Pole, 40 amps. 24 volt coil. Overload protection must be additionally provided. For use with DGS, SW, and MW Series.	

PART NO.	DESCRIPTION	QTY.
 Appearance may differ. [ACCP] CE-60-24	Contactor with enclosures. Ideal switching device for use with other control equipment. NEMA 1 Enclosures. Magnetic contactor with Load rating up to 600V Max., 3-Pole, 60 amps. 24 volt coil. Overload protection must be additionally provided. For use with DGS, SW & MW Series.	

NOTE: Installer to provide overload protection for all infrared heaters.

NOTE: Additional contactor sizes and coil voltages are available. Please contact factory for pricing and availability.

For sample wiring using contactor panels with on/off controls see page 20.

Electric Heater Control Options

MWC-##

Variable Heat Controller



- Can be used on **DGS, MW2, & BAH Series**.
- On-off with heater output modulation.
- 120 Volt rated for 1600 watts.
- 240 Volt rated for 3200 watts.
- Typically used for 1 or 2 smaller heaters.
- Contactors not needed in conjunction with these.

SMWC-##

Variable Heat Controller



- Can be used on **DGS, SW2, MW2, & BAH Series**.
- On-off with heater output modulation.
- 120 Volt rated for 1800 watts.
- 240 Volt rated for 3600 watts.
- Typically used for 1 or 2 smaller heaters.
- Contactors not needed in conjunction with these.





SCR-##

SCR Controller

- Can be used on **DGS, SW2, MW2, & BAH Series**.
- 208V, 240V, and 480V available in 30 and 80 Amp models.
- Used for heater output modulation.
- Comes standard with dial potentiometer.
- Potentiometer can be mounted outside of enclosure but the SCR panel must be located in a protected area.
- Factory wired with millisecond fuses.
- ½ second soft start.
- Available for use on 2-10vdc or 4-20ma operation from building management control.
- Oversized SCR's
- Contactors not needed in conjunction with these.

PART NO.	DESCRIPTION	DIMENSIONS			WEIGHT (LBS.)	QTY.
		DEPTH	WIDTH	HEIGHT		
MWC-16	Variable heat controller 120 Volt; 15 Amp. 1600 Watts max.	3" (76 mm)	5" (127 mm)	5" (127 mm)	3 lbs (1.5 kg)	
MWC-32	Variable heat controller 208/240 Volt; 15 Amp. 3200 Watts max.	3" (76 mm)	5" (127 mm)	5" (127 mm)	3 lbs (1.5 kg)	
SMWC-18	Variable heat controller 120 Volt; 15 Amp. 1800 Watts max.	3.5" (89 mm)	4" (102 mm)	5" (127 mm)	3 lbs (1.5 kg)	
SMWC-36	Variable heat controller 208/240 Volt; 15 Amp. 3600 Watts max.	3.5" (89 mm)	4" (102 mm)	5" (127 mm)	3 lbs (1.5 kg)	
SCR208-30-1	SCR controller. Single-phase 208/240 Volt. 30 Amp max. Enclosure included.	8" (203 mm)	10" (254 mm)	12" (305 mm)	15 lbs (7 kg)	
SCR208-30-3	SCR controller. Three-phase 208/240 Volt. 30 Amp max. Enclosure included.	9" (229 mm)	16" (406 mm)	20" (508 mm)	40 lbs (18 kg)	
SCR208-80-3	SCR controller. Three-phase 208/240 Volt. 80 Amp max. Enclosure included.	9" (229 mm)	20" (508 mm)	30" (762 mm)	50 lbs (23 kg)	
SCR480-30-3	SCR controller. Three-phase 480 Volt. 30 Amp max. Enclosure included.	9" (229 mm)	16" (406 mm)	20" (508 mm)	40 lbs (18 kg)	
SCR480-80-3	SCR controller. Three-Phase 480 Volt. 80 Amp max. Enclosure included.	9" (229 mm)	20" (508 mm)	30" (762 mm)	50 lbs (23 kg)	
SCR-MA-AO	Add-on option for SCR Series controllers to allow 4-20 ma control.					
SCR-DCV-AO	Add-on option for SCR Series controllers to allow 2-10 Volts DC control.					

PART NO.	DESCRIPTION	QTY.
 [ACCP] VHC-3	Variable heat controller suitable for up to a 3kW of infrared heater at 208-240V supply. Single phase. Integral ON/OFF switch. Fully adjustable power setting. High reliability triac used. Must be mounted in a protected area.	

PART NO.	DESCRIPTION	QTY.
 [ACCP] TC-6	Push button timer control. Suitable for up to 5kW - 6kW of infrared heaters at 208 - 240V supply, Single phase. Electronic soft start - extends lamp life. Tamper-proof Push Button. Fully adjustable time delay from 5 to 70 minutes. Red LED indicator when active. Waterproof (IP55 rated). Simple to install.	
 [ACCP] MS-3	Motion sensor utilizes passive infrared technology to detect heat radiation of moving human bodies and will activate for a user-determined time period (2-18 mins.) Suitable for up to 2.5 kW - 3kW at 208 - 240V. Manual ON/OFF override. Waterproof (IP55). For wall or ceiling mount.	

Replacement Lamp Elements

SW2 SERIES REPLACEMENT LAMP ELEMENTS [PPE]

	LAMP PART NO.	VOLTS	WATTS /LAMP	FOR USE WITH	LAMP LENGTH	SHIP WEIGHT	QTY.
CLEAR (WHITE) LAMP	EL-070A	120	1,600	A16W	24" (610 mm)	2 lbs (0.9 kg)	
	EL-071A	208	1,600	B16W	24" (610 mm)	2 lbs (0.9 kg)	
	EL-072A	208	2,500	B25W	33" (838 mm)	3 lbs (1.4 kg)	
	EL-073A	240	1,600	C16W	24" (610 mm)	2 lbs (0.9 kg)	
	EL-074A	240	2,500	C25W	33" (838 mm)	3 lbs (1.4 kg)	
	EL-075A	480	1,600	G16W	24" (610 mm)	2 lbs (0.9 kg)	
	EL-076A	480	2,500	G25W	33" (838 mm)	3 lbs (1.4 kg)	
	EL-077A	480	3,650	G36W	46" (1168 mm)	4 lbs (1.8 kg)	
	EL-078A	575	3,800	H38W	46" (1168 mm)	4 lbs (1.8 kg)	
REDUCED GLARE (RUBY) LAMP	EL-080A	120	1,600	A16R	24" (610 mm)	2 lbs (0.9 kg)	
	EL-081A	208	1,600	B16R	24" (610 mm)	2 lbs (0.9 kg)	
	EL-082A	208	2,500	B25R	33" (838 mm)	3 lbs (1.4 kg)	
	EL-083A	240	1,600	C16R	24" (610 mm)	2 lbs (0.9 kg)	
	EL-084A	240	2,500	C25R	33" (838 mm)	3 lbs (1.4 kg)	
	EL-085A	480	1,600	G16R	24" (610 mm)	2 lbs (0.9 kg)	
	EL-086A	480	2,500	G25R	33" (838 mm)	3 lbs (1.4 kg)	
	EL-087A	480	3,650	G36R	46" (1168 mm)	4 lbs (1.8 kg)	
	EL-088A	575	3,800	H38R	46" (1168 mm)	4 lbs (1.8 kg)	

MW2 SERIES REPLACEMENT LAMP ELEMENTS [PPE]

LAMP PART NO.	VOLTS	WATTS /LAMP	FOR USE WITH	LAMP LENGTH	SHIP WEIGHT	QTY.
EL-1070	120	750	A07	24" (610 mm)	2 lbs (0.9 kg)	
EL-1072	208	750	B07	24" (610 mm)	2 lbs (0.9 kg)	
EL-1074	240	750	C07	24" (610 mm)	2 lbs (0.9 kg)	
EL-1078	120	1,250	A12	33" (838 mm)	3 lbs (1.4 kg)	
EL-1080	208	1,250	B12	33" (838 mm)	3 lbs (1.4 kg)	
EL-1082	240	1,250	C12	33" (838 mm)	3 lbs (1.4 kg)	
EL-1086	120	2,000	A20	46" (1168 mm)	4 lbs (1.8 kg)	
EL-1088	208	2,000	B20	46" (1168 mm)	4 lbs (1.8 kg)	
EL-1090	240	2,000	C20	46" (1168 mm)	4 lbs (1.8 kg)	
EL-1092	480	2,000	G20	46" (1168 mm)	4 lbs (1.8 kg)	
EL-1094	575	3,000	H30	46" (1168 mm)	4 lbs (1.8 kg)	

DGS SERIES REPLACEMENT LAMP ELEMENTS [PPE]

LAMP PART NO.	VOLTS	WATTS /LAMP	FOR USE WITH	LAMP LENGTH	SHIP WEIGHT	QTY.
EL-15A	120	1,500	DGS-Z1-A15	13" (330 mm)	2 lbs (0.9 kg)	
EL-20C	230	2,000	DGS-Z1-C20	13" (330 mm)	2 lbs (0.9 kg)	
EL-15C	230	1,500	DGS-Z2-C30	13" (330 mm)	2 lbs (0.9 kg)	

BAH SERIES REPLACEMENT LAMP ELEMENTS [PPE]

LAMP PART NO.	VOLTS	WATTS /LAMP	FOR USE WITH	LAMP LENGTH	SHIP WEIGHT	QTY.
QT-18-A-05	120	500	BAH-18-A-05	18" (457 mm)	5 lbs (2.3 kg)	
QT-25-A-10	120	1,000	BAH-25-A-10	25" (635 mm)	5 lbs (2.3 kg)	
QT-25-B-10	208	1,000	BAH-25-B-10	25" (635 mm)	5 lbs (2.3 kg)	
QT-25-C-10	240	1,000	BAH-25-C-10	25" (635 mm)	5 lbs (2.3 kg)	
QT-35-A-17	120	1,750	BAH-35-A-17	35" (889 mm)	5 lbs (2.3 kg)	
QT-35-B-17	208	1,750	BAH-35-B-17	35" (889 mm)	5 lbs (2.3 kg)	
QT-35-C-17	240	1,750	BAH-35-C-17	35" (889 mm)	5 lbs (2.3 kg)	
QT-45-B-25	208	2,500	BAH-45-B-25	45" (1143 mm)	7 lbs (3.2 kg)	
QT-45-C-25	240	2,500	BAH-45-C-25	45" (1143 mm)	7 lbs (3.2 kg)	
QT-60-B-30	208	3,000	BAH-60-B-30	60" (1524 mm)	7 lbs (3.2 kg)	
QT-60-C-30	240	3,000	BAH-60-C-30	60" (1524 mm)	7 lbs (3.2 kg)	
QT-60-C-40	240	4,000	BAH-60-C-40	60" (1524 mm)	7 lbs (3.2 kg)	
QT-60-D-40	575	4,000	BAH-60-D-40	60" (1524 mm)	7 lbs (3.2 kg)	

Standard 'White/Clear' Lamp Elements: 96% radiant delivered efficiency with high moisture and thermal shock resistance. Instantaneous heat-up and cool-down performance.

Glare Reducing 'Red' Lamp Elements: 96% radiant delivered efficiency with high moisture and thermal shock resistance. Ruby red sleeve is capable of reducing visible light up to 90%. Instantaneous heat-up and cool-down performance.

Limited Warranty: 1-year on SW2, MW2 and DGS Series replacement lamp elements. 90-days on replacement BAH Series lamp elements.

CONTACTOR PANELS WITH ON/OFF CONTROLS WIRING EXAMPLES

Single phase service wiring example using a contactor panel, low voltage on/off control and external step down transformer.

SINGLE PHASE SERVICE

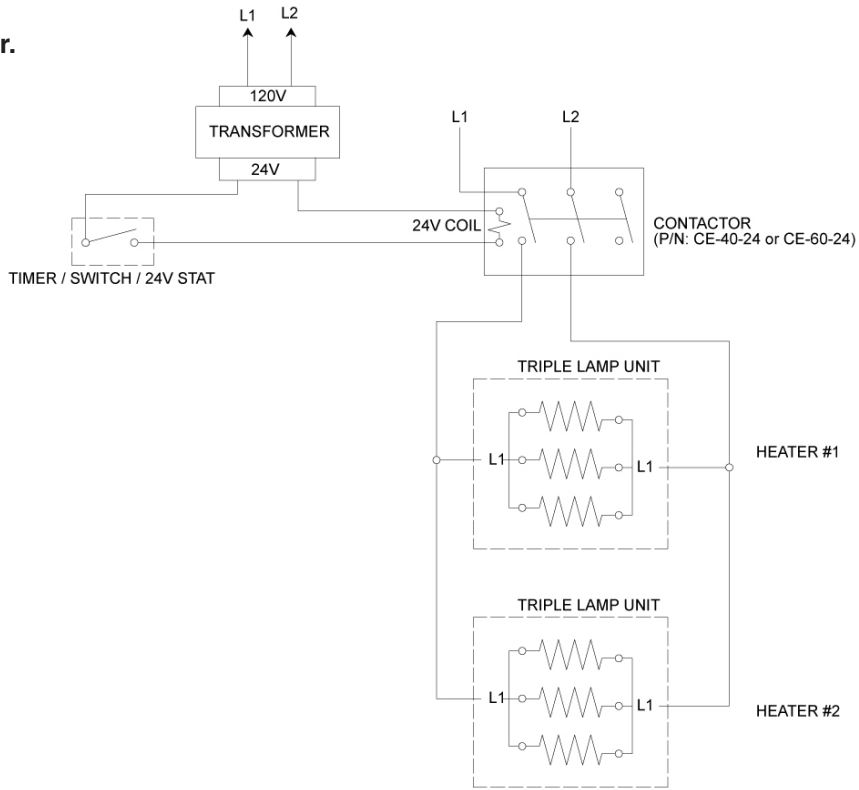

Three phase service wiring example using a contactor panel, low voltage on/off control and external step down transformer.

THREE PHASE SERVICE

