

DST Series Installation Manual

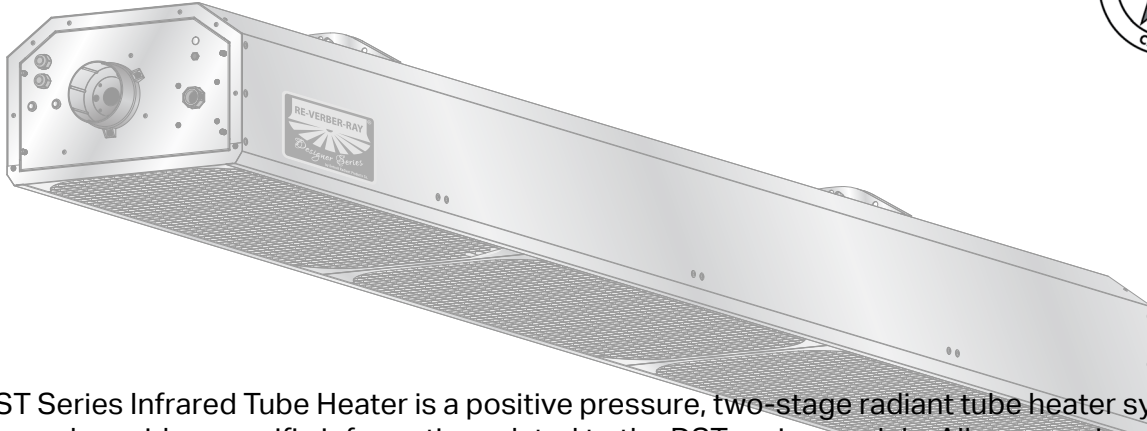

The DST Series Infrared Tube Heater is a positive pressure, two-stage radiant tube heater system. This manual provides specific information related to the DST series models. All persons involved with the installation, operation, and maintenance of the heater system must read and understand the information in this manual.

⚠ WARNING



Improper installation, adjustment, alteration, service, or maintenance can cause property damage, injury, or death. Read the installation, operation, and maintenance instructions thoroughly before installing or servicing this equipment.

This heater **must** be installed and serviced by trained gas installation and service personnel only. Failure to comply could result in personal injury, asphyxiation, death, fire, or property damage.



Do not store or use gasoline or other flammable vapors and liquids in the vicinity of this or any other appliance.

In locations used for the storage of combustible materials, signs must be posted to specify the maximum permissible stacking height to maintain the required clearances from the heater to the combustibles. Signs must either be posted adjacent to the heater thermostats or, in the absence of such thermostats, in a conspicuous location.



Do not use this heater in indoor living or sleeping quarters, etc.! Installation of a tube heater system in residential indoor living spaces may result in property damage, serious injury, asphyxiation, or death.

For Your Safety

If you smell gas:

- Do not try to light any appliance.
- Do not touch any electrical switch.
- Do not use any phone in your building.
- Immediately call your gas supplier from a neighbor's phone.
- Follow the gas supplier's instructions.
- If you cannot reach your gas supplier, call the fire department.

INSTALLER: Present this manual to the end user.

Keep these instructions in a clean and dry place for future reference.

Model#: _____ Serial #: _____
(located on rating label)

Contents

1.0 Introduction	3
Overview	3
Heater Components	3
Specifications	3
Safety Labels and Their Locations	4
2.0 Safety	6
Warning Symbols	6
Applications	6
Standards, Certifications, and Government Regulations	7
Clearances to Combustibles	8
3.0 Installation	10
Design Considerations and Prechecks	10
Recommended Mounting Heights and Coverages	11
Heater Placement and Suspension	12
Sway Bracing for High Air Movement and Outdoor Applications	13
Venting	14
Replacing Existing Equipment	14
General Venting Requirements	15
Vertical Venting (Category I)	17
Horizontal Venting (Category III)	18
Common Venting (Category I)	20
Unvented Operation	21
Installation of Exhaust Hood When not Venting Through Roof or Sidewall	21
General Combustion Air Requirements	22
Gas Supply Installation Instructions	25
Leak Testing	30
Electrical Requirements and Wiring Diagrams	31
Internal Wiring Diagram	31
Field Wiring Supply Voltage	32
Thermostat Connection	33
Unit Start-up (Commissioning)	34
Pre-Start Up Checks	34
Verify Proper Inlet Pressure	35
Verify Manifold Pressure	36
Prior to Leaving the Job Site	38
4.0 Operation	39
Operating Instructions	39
Sequence of Operation	40
Diagnostics	40
LED Operation	41
5.0 Maintenance	42
Routine Maintenance and Inspection	42
Troubleshooting Flowchart	44
Heater Assembly Components	48
Limited Warranty Terms and Conditions	50
Kit Contents	52

1.0 Introduction

Overview

The intent of this manual is to provide information regarding safety, design guidelines, installation, operation, and maintenance of the tube heater. You must read and understand the instructions and all safety warnings before installing the tube heater. This manual is property of the owner, and must stay with the owner or unit after the installation is complete.

Heater Components

Prior to installation, verify that the heater's gas type and voltage (as listed on the rating plate) match that of your application. Also verify that you have received all heater components included with your radiant tube heater. Refer to page 52 for a list of the kit contents for your series heater. Materials not included in the heater kit contents (e.g., screws, vent material, terminals, etc.) are the responsibility of the installer. Notify your product representative or Detroit Radiant Products of any discrepancy or missing kit contents prior to installing unit.

Specifications

Chart 1.1 • DST Series Specifications

Model Number	Gas Type	BTU/h High Fire	BTU/h Low Fire	Typ. or Rcmd. Mounting Heights*	Unit Weight	Overall Unit Length	Application
DST-60N	Natural Gas	60,000	40,000	8' to 14'	150 lbs.	119"	Indoor & Outdoor
DST-60P	Propane	60,000	50,000	8' to 14'	150 lbs.	119"	Indoor & Outdoor
DST-80N	Natural Gas	80,000	50,000	9' to 15'	150 lbs.	119"	Outdoor

*Typical or recommended mounting heights are provided as a guideline. Actual conditions may dictate variations from this data.

⚠ WARNING



Read and understand all safety information and warnings in this manual before installation, operation, and maintenance of the radiant tube heater system.

Safety Labels and Their Locations

Product safety signs or labels should be replaced by the product user when they no longer are legible. Contact either your local distributor or the product manufacturer for obtaining replacement signs or labels.

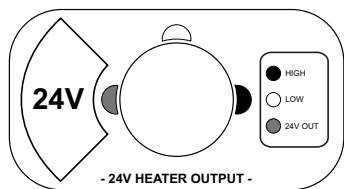

F/N: LLV3EP4

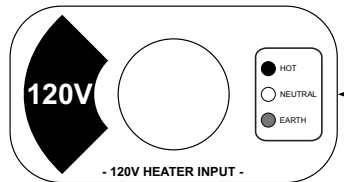

F/N: LLV3EP1

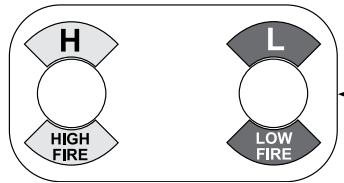

F/N: LLV2EP9

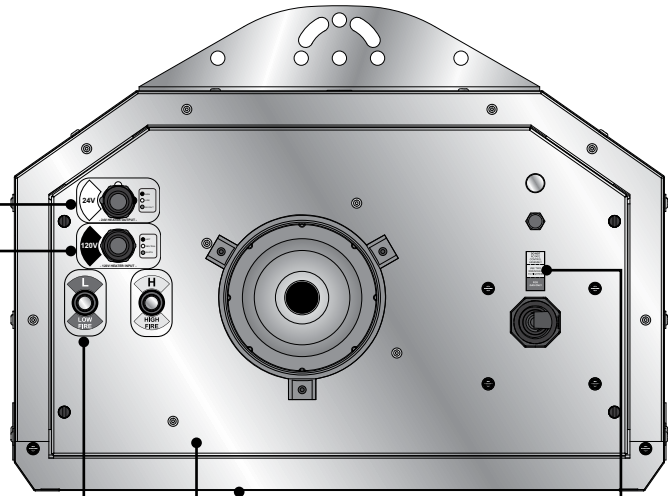

End Panel

DO NOT ROTATE CONTROL ASSEMBLY

USE TWO WRENCHES TO TIGHTEN

FOR GAS ONLY

DO NOT ROTATE CONTROL ASSEMBLY

USE TWO WRENCHES TO TIGHTEN

FOR GAS ONLY

F/N: LLTB018 (Natural Gas)
LLTB019 (Propane Gas)

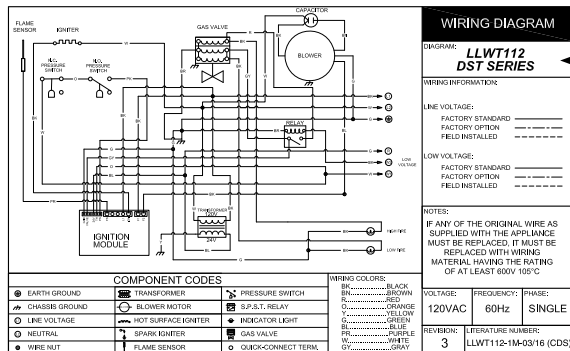

DST Series Internal Wiring Diagram
(Located in control box compartment)
F/N: LLWT112

DST-80N Serial No.: 1611XXXXXXXXX 0001

Production Code: DST Stock: None
Version: 01.16 Add-On: N/A

Data on this label is for the model shown on this label. If your heater has been converted, this information is not accurate. Please contact the factory for assistance.

BURNER COMPONENTS: (Specify TP.#s)					
Gas Valve:	Two-Stage	3140	Diag. Light:	None	N/A
Control Board:	Ignition Control	8518	Term. Block:	None	N/A
Wire Harness:	3 PCB Harness	3552	Transformer:	None	N/A
N.O. Switch:	None	N/A	Fuel Lip:	None	SEA
N.C. Switch:	None	N/A	Gas:	50Hz - 120V	558
N.C. Vt. Outlet:	None	N/A	Alt. Fan:	When Specified	N/A
Diag. Switch:	None	N/A	Diag.:	None	N/A
Ign. Vt. Outlet:	IS2016051P5169	264E	24 Volt In:	None	264
Igniter:	None	50	24 Volt In:	None	335
Burner:	High	2018	Gas In:	120V Cord	83
Gas Tube:	4" Gas	1060	Gas In:	7/8" FC Flare	83
Val. Lights:	Yellow - 120V	828	Gas Vt. Outlet:	None	

HEATER Office Type: C1 C2 C3 Internal Use Only:
TYPE: Gas: TP-2049 3 3 1 Electric: LLWT803 Special 1: 17
C1 Air: TP-444 1 1 SF 1 SF 1 SF Tag: None Special 2: 1718

For parts replacement information, contact factory at 586-756-0950 or visit www.dip-co.com/parts.

Bill of Materials
(Located in control box compartment)

Top Panel

LOW-INTENSITY INFRARED HEATER
RADIATEUR A INFRAROUGE A FAIBLE INTENSITE

DST-60N YMMREPCSHPPE### 3/16

60,000 BTU/H (17.6 kW) 5.5 GPM (20.8 L) 120 V

40,000 BTU/H (11.7 kW) 14.0 GPM (53.0 L) 1.2

NATURAL GAS 5.0 GPM (18.8 L) SINGLE

CATEGORY 22 60" (1524 mm)

ANSI Z83.26-2014 • CSA 2.34-2016 Low-Intensity Infrared Heater
ANSI Z21.88-2008 • CSA 2.33-2008 (R2014) Vented Gas-Fired Space Heating Appliances
A.G.A. REQUIREMENTS: 7-99, Garage Heater

FOR U.S.A. THIS HEATER IS APPROVED FOR ALTITUDES OF 0-2000 FT. IN CANADA FOR ALTITUDES UP TO 4500 FT. (13716 M) ABOVE SEA LEVEL.
ALC-CONFORMING PARTS LIST IS AVAILABLE AT WWW.REVERBER-RAY.COM

DETROIT RADIANT PRODUCTS COMPANY
21400 HOOPER ROAD - WARREN, MI 48099
(586) 756-0950 www.reverber-ray.com

RE-VERBER-RAY
Designer Series
by Detroit Radiant Products Co.

⚠ DANGER
FIRE HAZARD. Always maintain published clearances to combustibles. In locations used for the storage of combustible materials, signs must be posted. Consult manual for additional guidelines.

CLEARANCES TO COMBUSTIBLES (in inches)

MODEL NO.	MOUNTING ANGLE*	SIDE(S)			
		TOP	FRONT	BEHIND	BELOW**
DST-60	0°	12	19	19	16, 66
	30°	14	45	24	16, 45
DST-80	0°	15	26	26	16, 77
	30°	16	74	31	16, 74

SIDE VIEW **END VIEW 0° Mounting** **END VIEW 30° Mounting**

* Heaters mounted on an angle between 1° and 30° must maintain clearances posed for 0° or 30°, whichever is greater.
** This heater must be installed at least 79" above the floor/ground level (as applicable).

Rating Plate **Designer Series Logo Plaque** **DST Series Clearances to Combustibles Label**

F/N: LLOGO026 F/N: LLTCL016b

FOR YOUR SAFETY READ BEFORE OPERATING

WARNING: Improper installation, adjustment, alteration, service, or maintenance can cause property damage, injury, or death. Read the installation, adjustment, alteration, service, and maintenance instructions thoroughly before installing or servicing this appliance.

WARNING: If you do not follow these instructions exactly, a fire or explosion may result causing property damage, personal injury, or loss of life.

WARNING: The use and storage of gasoline and other flammable vapors and liquids in open containers in the vicinity of the appliance is hazardous.

WARNING: Disconnect electric power before servicing. Unit must be wired in accordance with diagram provided.

This appliance must be installed in accordance with the manufacturer's instructions and local codes. In the absence of local codes, follow the National Fuel Gas Code (ANSI Z223.1) or the CAN/CSA B149 Installation Codes.

- This appliance does not have a pilot. It is equipped with an ignition device which automatically lights the burner. Do not attempt to light the burner by hand.
- BEFORE OPERATING** smell all around the appliance area for gas. Be sure to smell next to the floor because some gas is heavier than air and will settle on the floor.
WHAT TO DO IF YOU SMELL GAS:
 - Do not try to light any appliance.
 - Do not touch any electrical switch; do not use any phone in the building.
 - Immediately call your gas supplier from a neighbor's phone. Follow the gas supplier's instructions.
 - If you cannot reach your gas supplier, call the fire department.
- Use only your hand to turn the manual shut-off knob. Never use tools. If the knob will not turn by hand, don't try to force it; call a qualified service technician. Forcing or attempting a repair may result in a fire or explosion.
- Do not use this appliance if any part has been under water. Immediately call a qualified service technician to inspect the appliance and to replace any part of the control system and any gas control which has been under water.

OPERATING INSTRUCTIONS

- STOP! Read the safety information in the manual prior to proceeding.
- Set the thermostat to the lowest setting.
- Turn off all electric power to the appliance.
- This appliance is equipped with an ignition device which automatically lights the burner. **DO NOT** try to light the burner by hand.
- Open the Access Panel.
- Move the gas control switch to the "OFF" position.
- Wait five (5) minutes to clear out any gas. If you smell gas, **STOP!** Follow "B" in the safety information above on what to do if you smell gas. If you do not smell gas, proceed to the next step.
- Move the gas control switch to the "ON" position.
- Close and secure the control access panel.
- Turn on all electric power to the appliance.
- Set thermostat to desired setting.
- If the appliance will not operate, follow the instructions **TO TURN OFF GAS TO APPLIANCE** and call your service technician or gas supplier.

TURN OFF GAS TO APPLIANCE

- STOP! Read the safety information in the manual prior to proceeding.
- Set the thermostat to the lowest setting.
- Turn off all electric power to the appliance.
- Turn the manual shut-off valve located outside of the unit to the closed position.
- Open the access panel.
- Turn the gas valve switch to the "OFF" position. Do not force.
- Close and secure the access panel.

Gas Inlet Gas Control Switch Shown in "OFF" Position

⚠ WARNING

Improper installation, adjustment, alteration, service, or maintenance can cause property damage, injury, or death. Read and understand the installation, operating, and maintenance instructions thoroughly before installing or servicing this equipment.

This heater must be installed and serviced by a trained gas appliance installer and service personnel only. The installation of this heater must conform to the requirements of the manual and local building codes. In absence of such codes, refer to the latest edition of the National Fuel Gas Code, NFPA 54 (ANSI Z223.1).

This is **NOT** an explosion-proof heater. Where there is the possibility of exposure to flammable vapors or dusts, consult the local authorities, fire insurance carrier, or other authorities for approval of the proposed installation. **DO NOT** install in explosive environments.

VENTING: This heater **MUST** be properly connected to a manufacturer's approved vent system and comply with the following requirements:
DO NOT exceed 20 feet of vent length or place more than two (2) 90° directional changes in the venting system. See DST Series Manual (L10DST) for complete venting instructions.

This heater requires fresh air for safe operation and must be installed so there are provisions for adequate combustion and ventilation air. **DO NOT** operate this heater without installing the exhaust/air intake vents supplied with the heater. Refer to the installation instructions for installation details. Operation of this heater when not connected to a properly installed and maintained venting system can result in carbon monoxide (CO) poisoning and possible death.

When operating this unit in unvented applications (Non-residential only) a minimum ventilation rate of 4 CFM per 1,000 BTU/h is required to properly displace the products of combustion.

GAS CONNECTION: Allowance must be made for the system to expand and contract as this unit operates. A flexible gas connection of approved type is required. Flexible stainless steel gas connector installed in one plane, and without sharp bends, kinks, or twists is required.

WARNING: The connector **MUST** be installed in a 'C' configuration. Use only the connector that is furnished with this heater. Consult installation manual for further instructions.

SIDE VIEW END VIEW

⚠ CAUTION

This heater must be installed in accordance with the manufacturer's instruction and local codes, if any. In absence of local codes, follow the latest edition of the National Fuel Gas Code, NFPA 54 (ANSI Z223.1) or the CAN/CSA B149 installation codes.

Hot while in operation. DO NOT Touch. Keep children, clothing, and combustible materials away. **DO NOT** store combustible materials under this heater while in operation.

Keep burner and control compartment clean. See installation and operating instructions accompanying heater.

APPLICATION: Minimum mounting height 79" above finished floor.

If this appliance is installed in one or more of the following locations, then the installation must be in accordance with the latest edition of the applicable standard(s):

- Aircraft Hangers - ANSI / NFPA 409
- Parking Structure - ANSI / NFPA 88A
- Repair Garages - ANSI / NFPA 88B

DST Mounting Height Label

F/N: LLTCL016a

2.0 Safety

Read and understand all safety information and warnings in this manual prior to installation, operation, and maintenance of this tube heater. Warnings indicate a potentially hazardous situation which, if not avoided, could result in death or injury.

⚠ WARNING



Improper installation, adjustment, alteration, service, or maintenance can cause property damage, serious injury, or death. Read and understand the installation, operating, and maintenance instructions thoroughly before installing or servicing this equipment. Only trained qualified gas installation and service personnel may install or service this equipment.

Warning Symbols

Safety is the most important consideration during installation, operation, and maintenance of the heater. You will see the following symbols and signal words when there is a hazard related to safety or property damage.

⚠ WARNING

Warning indicates a potentially hazardous situation which, if not avoided, could result in death or injury.

⚠ CAUTION

Caution indicates a potentially hazardous situation which, if not avoided, could result in minor or moderate injury.

NOTICE

Notice indicates a potentially hazardous situation which, if not avoided, could result in property damage.

Applications

This is **not** an explosion proof heater. This heater may not be used in a Class 1 or Class 2 Explosive Environment. Consult your local fire marshal, insurance carrier, and other authorities for approval if the proposed installation is in question.

Patio (All Models)

This patio heater is specifically designed to provide heated comfort in an outdoor environment. When properly integrated into a patio design, the heaters generally increase the comfort levels.

Residential (60,000 BTU/h Models Only)

This heater is Design Certified under CSA Requirements for residential radiant tube heaters (No. 7-89). Not for use in the residential indoor living areas or sleeping quarters.

⚠ WARNING

Not For Use in Indoor Living Spaces. Installing this unit in residential indoor living spaces or sleeping quarters, such as bedrooms or basements, may result in property damage, serious injury, or death.

Commercial / Industrial (60,000 BTU/h Models Only)

Unless otherwise indicated, tube heaters are designed and certified for use in industrial and commercial buildings such as warehouses, manufacturing plants, aircraft hangars, and vehicle maintenance shops. For maximum safety, the building must be evaluated for potential problems before installing the heating system. A critical safety factor to consider before installation is the clearances to combustibles.

! WARNING

California Proposition 65

This product can expose you to chemicals including lead and carbon monoxide, which are known to the State of California to cause birth defects or other reproductive harm.

For more information, go to www.P65Warnings.ca.gov.

Standards, Certifications, and Government Regulations

Installation of this tube heater must conform with all applicable local, state, and national specifications, regulations, and building codes. Contact the local building inspector and/or fire marshal for guidance.

In the absence of local codes, the installation must conform to the latest edition of:

United States: National Fuel Gas Code, ANSI Z223.1 (NFPA 54).

Copies of the Standards can be viewed or purchased at www.nfpa.org.

Public Garages and Maintenance Facilities (60,000 BTU/h Models Only)

This heater must be installed in accordance with the latest edition of the Standard for Parking Structures, ANSI/NFPA 88A or the Code for Motor Fuel Dispensing Facilities and Repair Garages ANSI/NFPA 88B.

- Heaters must not be installed less than 8 ft. (2.4 m) above the floor. Minimum clearances to combustibles must be maintained from vehicles parked below the heater.
- When installed over hoists, minimum clearances to combustibles must be maintained from the upper most point of objects on the hoist.

Aircraft Hangars (60,000 BTU/h Models Only)

This heater must be installed in accordance with the latest edition of the Standard for Aircraft Hangars, ANSI/NFPA 409.

- In aircraft storage and servicing areas, heaters shall be installed at least 10 ft. from above the upper surface of wings or of the engine enclosures of the highest aircraft that may be housed in the hangar. The measurement shall be made from the wing or engine enclosure, whichever is higher from the floor, to the bottom of the heater.
- In areas adjoining the aircraft storage area (e.g., shops, offices) the bottom of heaters shall be installed no less than 8 ft. (2.4 m) above the floor.
- Suspended or elevated heaters shall be located in spaces where they shall not be subject to damage by aircraft, cranes, movable scaffolding or other objects.

Provisions shall be made to assure accessibility to suspended tube heaters for recurrent maintenance purposes.

Clearances to Combustibles

A critical safety factor to consider before installation is the clearances to combustibles. **Clearance to combustibles** is defined as the minimum distance you must have between the tube surface, or reflector, and the combustible item. Considerations must also be made for moving objects around the tube heater. The following is a partial list of items to maintain clearances from:

Combustible items:

- Wood
- Paper
- Fabric
- Chemicals
- Paint
- Plastic
- Parked vehicles
- Gasoline
- Storage racks

Moving Objects:

- Overhead doors
- Vehicle lifts
- Cranes
- Hoists

Hazards:

For maximum safety the building must be evaluated for hazards before installing the heating system. Examples include, but are not limited to:

- Gas and electrical lines
- Combustible and explosive materials
- Chemical storage areas
- Areas of high chemical fume concentrations
- Provisions for accessibility to the heater
- Adequate clearances around air openings
- Combustion and ventilating air supply
- Vehicle parking areas
- Vehicles with lifts or cranes
- Storage areas with stacked materials
- Lights
- Sprinkler heads
- Overhead doors and tracks
- Dirty, contaminated environment

! WARNING



Placement of explosive objects, flammable objects, liquids, and vapors close to the heater may result in explosion, fire, property damage, serious injury, or death. Do not store or use explosive objects, liquids, and vapor in the vicinity of the heater.

! CAUTION

Children and adults should be alerted to the hazards of high surface temperatures and should stay away to avoid burns or clothing ignition.

Young children should be carefully supervised when they are in the same space as the heater.

Clothing or other flammable materials should not be hung from the heater or placed on or near the heater.

Any guard or other protective device removed for servicing the heater must be replaced prior to operating the heater.

Installation and repair should be done by a qualified service person. The heater should be inspected before use and at least annually by a qualified service person. More frequent cleaning may be required as necessary. It is imperative that the control compartment, air passageways, and burner(s) of the heater be kept clean.

When installing the tube heating system, the minimum clearances to combustibles for your series tube heater and system configuration must be maintained. These distances are shown in Chart 2.1 on page 9 and on the burner control box. If you are unsure of the potential hazards, consult your local fire marshal, fire insurance carrier, or other qualified authorities on the installation of gas fired tube heaters for approval of the proposed installation.

In locations used for the storage of combustible materials, signs must be posted to specify the maximum permissible stacking height to maintain the required clearances from the heater to the combustibles. Signs must either be posted adjacent to the heater's thermostat or in a conspicuous location.

The stated clearances to combustibles represent a surface temperature of 90°F (50°C) above room temperature. Building materials with a low heat tolerance (such as plastics, vinyl siding, canvas, tri-ply, etc.) may be subject to degradation at lower temperatures. It is the installer's responsibility to ensure that adjacent materials are protected from degradation.

⚠ WARNING



Failure to comply with the stated clearances to combustibles may result in personal injury, property damage, and/or death.

Chart 2.1 • Clearances to Combustible Materials in Inches (see Figure 2.1)

Model Number	Mounting Angle*	Sides			Ends	Below**
		Top	Front	Behind		
DST-60	0°	12	19	19	16	66
	30°	14	45	24	16	45
DST-80	0°	15	26	26	16	77
	30°	16	74	31	16	74

* Heaters mounted on an angle between 0° and 30° must maintain clearances posted for 0° or 30°, whichever is greater.

** The minimum mounting height is 79" above floor level.

Figure 2.1 • Mounting Angles

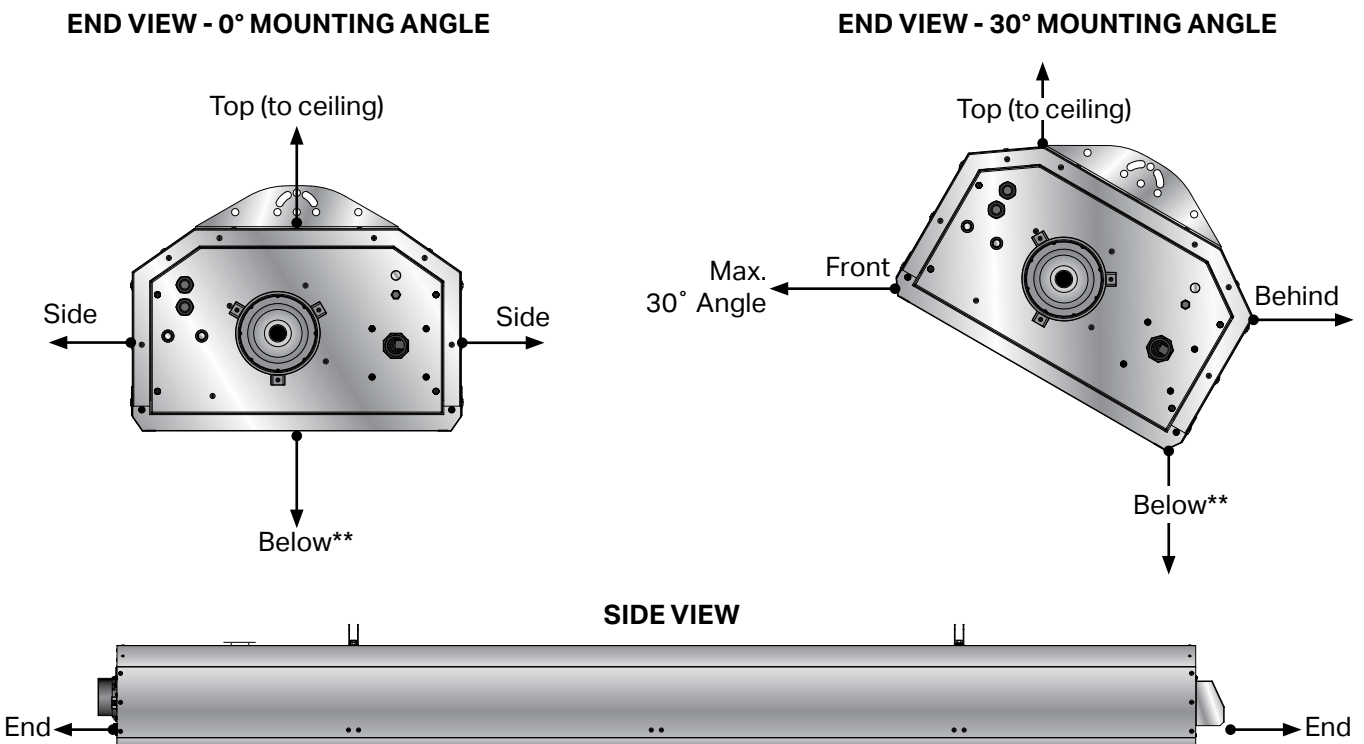

3.0 Installation

⚠ WARNING



Improper installation, adjustment, alteration, service, or maintenance can cause property damage, serious injury, or death.

Read and understand, the installation, operation, and maintenance instructions thoroughly before installing or servicing this equipment.

Only trained, qualified gas installation and service personnel may install or service this equipment.

Design Considerations and Prechecks

Placement of infrared heaters is influenced by many factors. Aside from safety factors, considerations such as the number of heaters or vent elbows that are allowed, maximum vent lengths, ducting of combustion air, and combining exhaust vents are a few examples. All installation manuals, along with national, state, provincial, and local codes, address these issues. It is critical that you read, understand, and follow all guidelines and instructions.

To ensure a properly designed heating system, a layout should be developed for the correct placement of the burner control box, tubes, vents, and combustion air intake ducts. Inspect and evaluate the mounting conditions, vent locations, gas supply, and wiring.

When designing an infrared radiant heating system, consider the following:

- Has the building's heat loss been evaluated?
- Does the design meet the needs of the space?
- Have recommended mounting heights been observed?
- Have all clearance to combustible situations been observed?
- Is the supply (burner) end of the heater located where more heat is required?
- Is it best to offset the heaters and/or rotate the reflectors towards the heat zone?
- Are extra guards, side shields, 'U' or 'L' reflector covers required?
- Does the heater require outside fresh air for combustion?
- Is the environment harsh or contaminated (requiring outside air for combustion)?
- Are chemicals or vapors a concern (requiring outside air for combustion or additional ventilation)?

IMPORTANT: Fire sprinkler heads must be located at an appropriate distance from the heater. This distance may exceed the published clearances to combustibles as posted on the heater. Certain applications may require the use of high temperature sprinkler heads or relocation of the heaters.

Sprinkler systems containing propylene glycol or other flammable substances are not to be used in conjunction with this heater without careful consideration for and avoidance of potential fire or explosion hazards. For further information consult NFPA 13.

The effective infrared surface temperature of a person or object may be diminished with wind velocities above 5 mph. The use of adequate wind barrier(s) may be required.

Figure 3.1 • Heater Dimensions

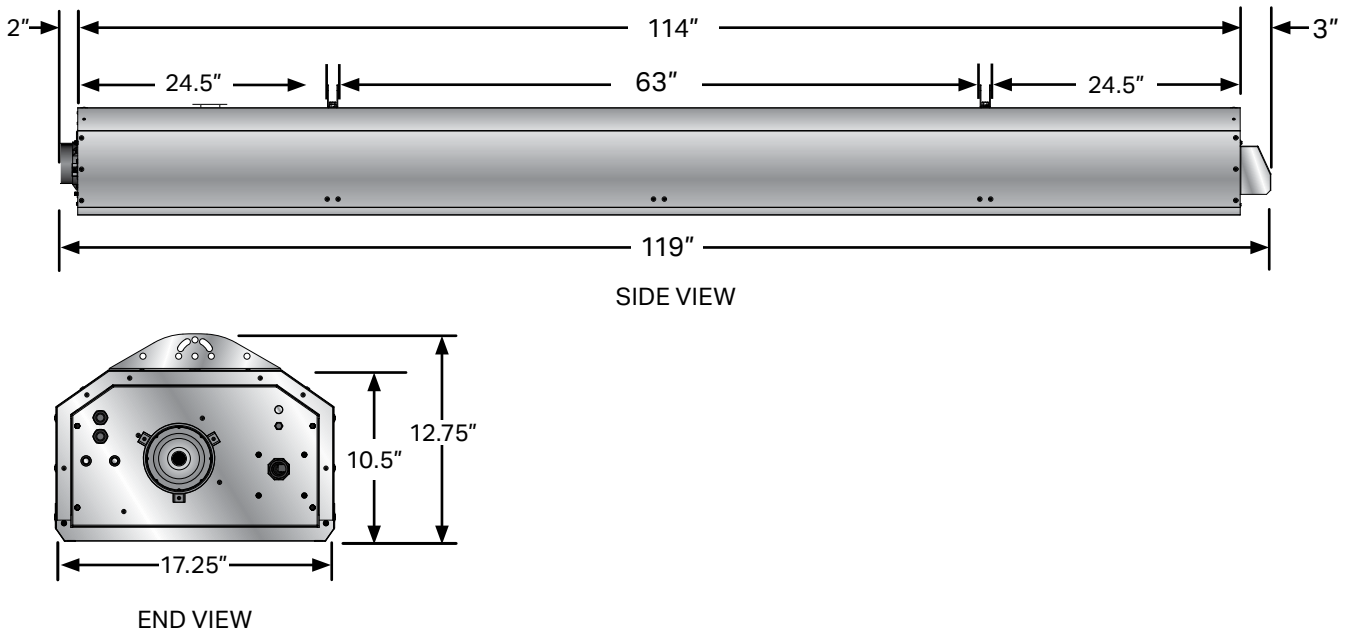

Chart 3.1 • Recommended Mounting Heights and Coverages for DST Series Heaters

NOTE: This chart is provided as a guideline. Actual conditions may dictate variation from this data.

Max. Input (BTU/h)	Typical or Recommended Mounting Height*	Coverage Area (LxW)	Distance Between Heaters (ft.) Dim. A	Distance Between Heater Rows Dim. B	Max. Distance Between Heaters and Wall - Dim. C
60,000	8' - 14'	20' x 12'	10' - 20'	20' - 40'	16'
80,000	9' - 15'	20' x 12'	10' - 20'	20' - 40'	16'

*Factory recommended mounting heights are listed as a guideline. If infrared heaters are mounted too low or too high, they may result in discomfort or lack of heat. Detroit Radiant Products Company generally recommends observing the recommended mounting heights to optimize comfort conditions. However, certain applications such as spot heating, freeze protection, outdoor patio heating or very high ceilings may result in the heaters being mounted outside of the factory recommended mounting heights.

Figure 3.2 • Mounting Height Dimensions (see Chart 3.1 for dimensions)

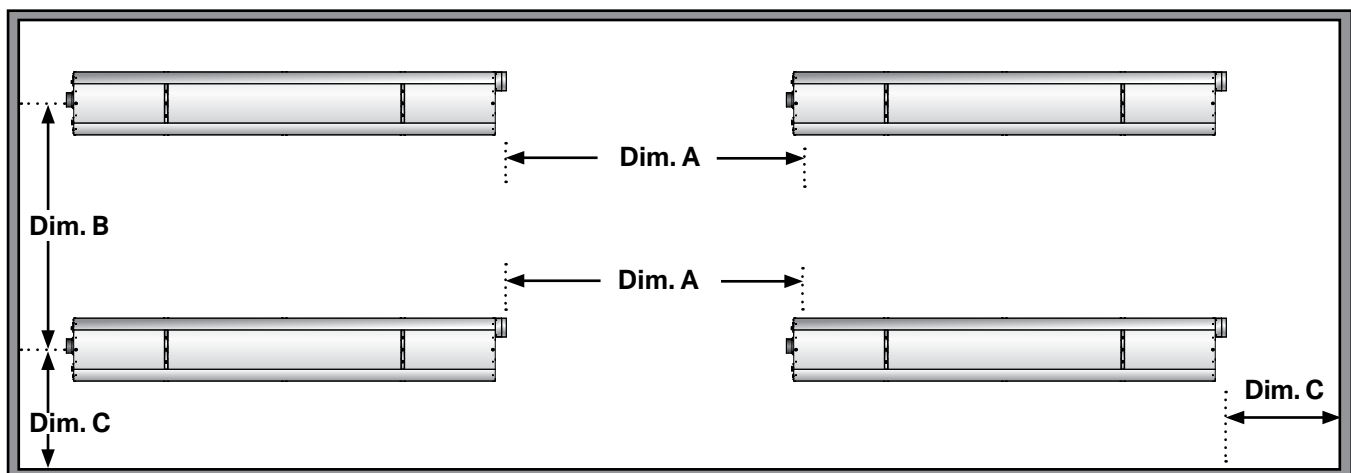

NOTE: Dimensions A, B, & C are based upon heaters hung at the factory recommended mounting height.

Heater Placement and Suspension

⚠ WARNING



Improper suspension of the tube heater may result in collapse and being crushed. Always suspend from a permanent part of the building structure that can evenly support the total force and weight of the heater.

Suspension of the heater must conform to applicable codes referenced in the Safety section and these instructions.

- ① Mark locations for hanging points.
- ② Prepare mounting surface. If necessary, weld blocks and drill holes.
- ③ Fasten bean clamp, screw hook, or other type of suspension anchor to hanging point.
- ④ Attach and close stainless steel S-hook and #2 stainless steel bulldog chain (P/N: THCS-DST) to anchor. Check that it is securely attached. **NOTE:** Threaded rod may be used.
- ⑤ Attach stainless steel S-hooks to hanging points on heater. Adjust chain lengths until heater is level and equal weight distribution is achieved.

Figure 3.3 • Mounting the Hangers

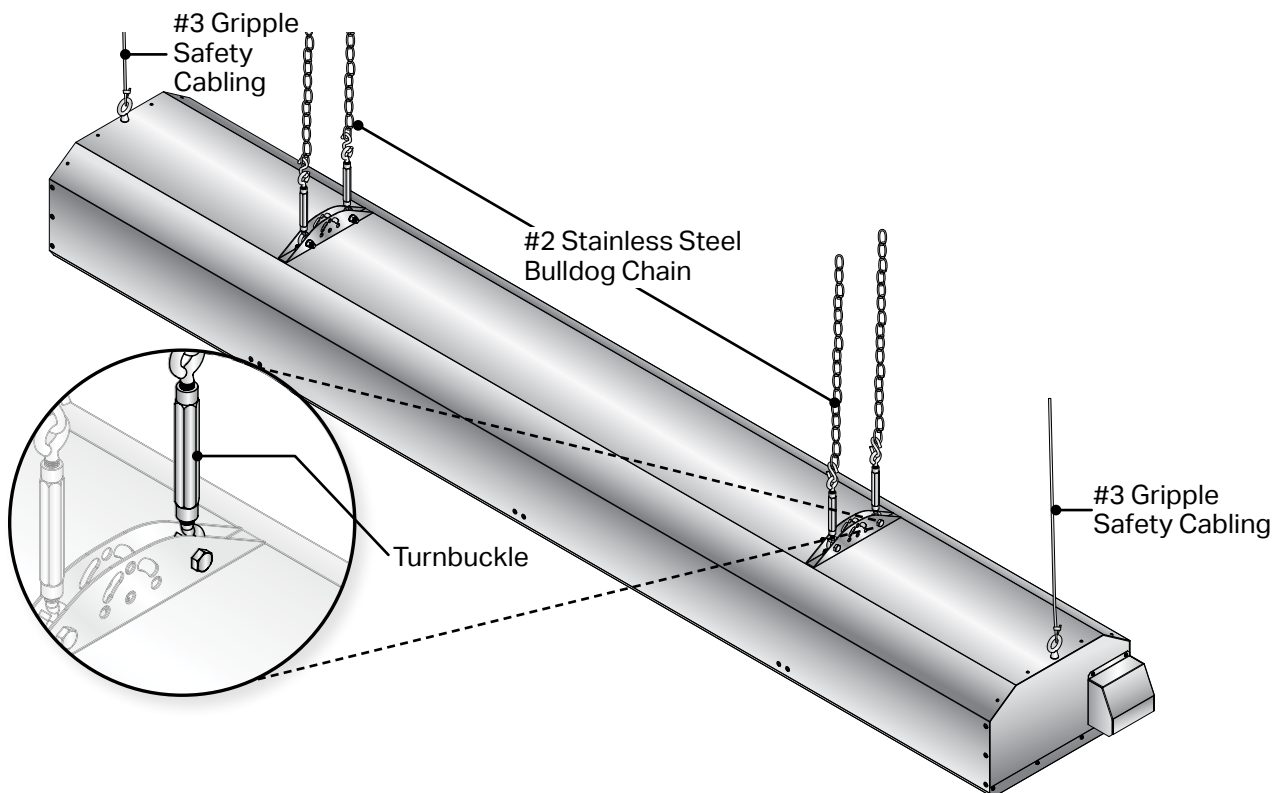

Sway Bracing for High Air Movement and Outdoor Applications

For high air movement and outdoor applications, install side restraints (Figure 3.4) to reduce side to side swaying. Side restraints should be installed so that they are angled at $45^\circ \pm 10^\circ$ and should be placed at every designated suspension point. It may be necessary to add additional support structures at the ceiling level for the connection of these side suspensions. Apply longitudinal (forward/backward) bracing at each end of the heater (field supplied). The desired suspension material shall have a minimum work load rating of 170 pounds.

Figure 3.4 • Heater with Sway Bracing Installation

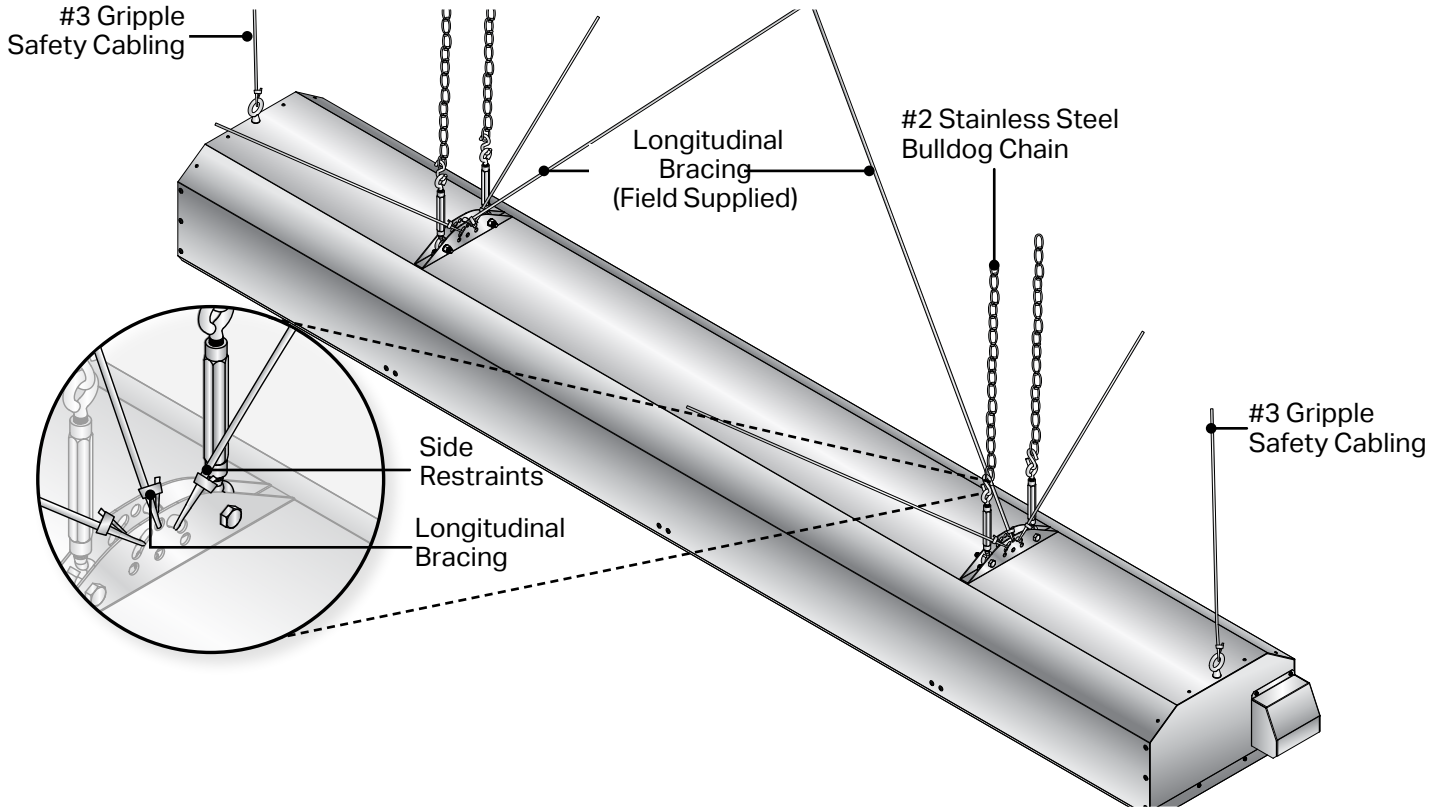

Venting (60,000 BTU/h Models Only)

The DST series tube heater (60,000 BTU/h models only) must be vented as described here to properly direct flue gases from the unit to the outside atmosphere. The venting can terminate vertically through the roof (up) or horizontally through a sidewall (sideways).

Follow these guidelines and all applicable codes for all models prior to installing the vent material. Local codes may vary.

In the absence of local codes, refer to:

United States: NFPA 54/ANSI Z223.1 (latest edition), National Fuel Gas Code, NFPA 30A, NFPA 52.

Canada: CAN/CGA B149.1 and B149.2 Installation Codes for Gas Burning Appliances.

! WARNING



Gas-fired heaters must be vented. A built in power exhauster is provided. Additional external power exhausters are not required or permitted.

Insufficient ventilation and/or improperly sealed vents may release gas into the building which could result in health problems, carbon monoxide poisoning, or death. Improper venting may result in fire, explosion, injury, or death.

! WARNING

Do not vent this appliance into another heater's vents or through a masonry chimney.

Do not use dampers in the heater vent pipe.

Single wall vent pipe must not pass through any unoccupied attic, inside wall, concealed space, or floor.

Un-insulated single wall vent pipe must not be used outdoors for venting appliances in regions where winter design temperature is below freezing.

Replacing Existing Equipment (60,000 BTU/h Models Only)

If the heater is replacing existing equipment and using an existing vent system, inspect the venting for proper size and horizontal pitch as directed in these instructions and the latest edition of the National Fuel Gas Code, ANSI Z223.1 (NFPA 54) or CSA B149.1 Installation Code.

Determine that there is no blockage or restriction, leakage, corrosion, or other deficiencies that can cause hazards. The vent pipe should be corrosion-resistant galvanized steel of a thickness that meets the National Fuel Gas Code. Minimum thickness for connectors varies depending on the pipe diameter. Never vent the DST series with PVC or plastic pipe.

! WARNING



If replacing an existing heater, vents may require re-sizing. Improperly sized venting systems can result in vent gas leakage or condensation. Refer to the National Fuel Gas Code ANSI Z223.1 (NFPA 54) or CSA B149.1 - latest edition. Failure to follow these instructions can result in serious injury or death.

General Venting Requirements (60,000 BTU/h Models Only)

The venting system for DST series heaters (60,000 BTU/h models only) may terminate horizontally through a sidewall or vertically through the roof, and may be individually or commonly vented. Configuration of the vent termination determines the category type. All model heaters must be installed in accordance to the requirements of this section, as well as the requirements of its category determination, as described in this manual. To determine your applications category type, review "Vertical Venting (Category I)" and "Horizontal Venting (Category III)" sections of this manual.

All DST Series 60,000 BTU/h Model Requirements:

- Exhaust vent pipe must be 4 inch nominal size.
- Use vent pipe material that is corrosion-resistant galvanized steel of a thickness that meets the National Fuel Gas Code.
- Do not exceed a maximum vent length of 20 feet.
- Maintain a minimum vent length of 3 feet.
- Maintain a minimum 12 inches of straight pipe from the flue outlet before any directional changes are made in the venting system.
- Have all vent pipe seams or connectors fastened together with at least three corrosion resistant sheet metal screws (field supplied).
- Maintain a 6 inch clearance around all single wall vent pipe from any combustible materials. For double-wall Type-B vent, follow the vent manufacturer's clearance to combustibles.
- The equivalent length for a 4 inch 90° elbow is 5 feet.
- Avoid using more than two 90° directional changes in the venting system.
- Suspend and secure all horizontal runs at points no greater than 3 feet apart.
- Vent termination must maintain a minimum distance of 6 feet from any mechanical air supply inlet.
- Vent must terminate a minimum of 4 feet below, 4 feet horizontally from, or 1 foot above any window or door that may be opened or gravity air inlet into the building.
- Vent must terminate a minimum of 4 feet above grade level and must extend beyond any combustible overhang. Vents adjacent to the public walkways must terminate a minimum of 7 feet above grade level.
- The vent terminal must be installed to prevent any blockage by snow and protect building material from degradation by flue gases.
- The vent cap must be a minimum of 6 inches from the sidewall of the building.
- Vent must be a minimum of 36 inches below or extend beyond any combustible overhang.
- Consult NFPA ANSI Z223.1 Gas Vent Termination criteria for vents that terminate on a roof pitch that exceeds 9:12.
- **Canada:** Vents must terminate a minimum of 3 feet from a window or door that may be opened, and a non-mechanical air supply inlet or combustion air inlet into the building.

Figure 3.5 • General Venting Requirements - Side View

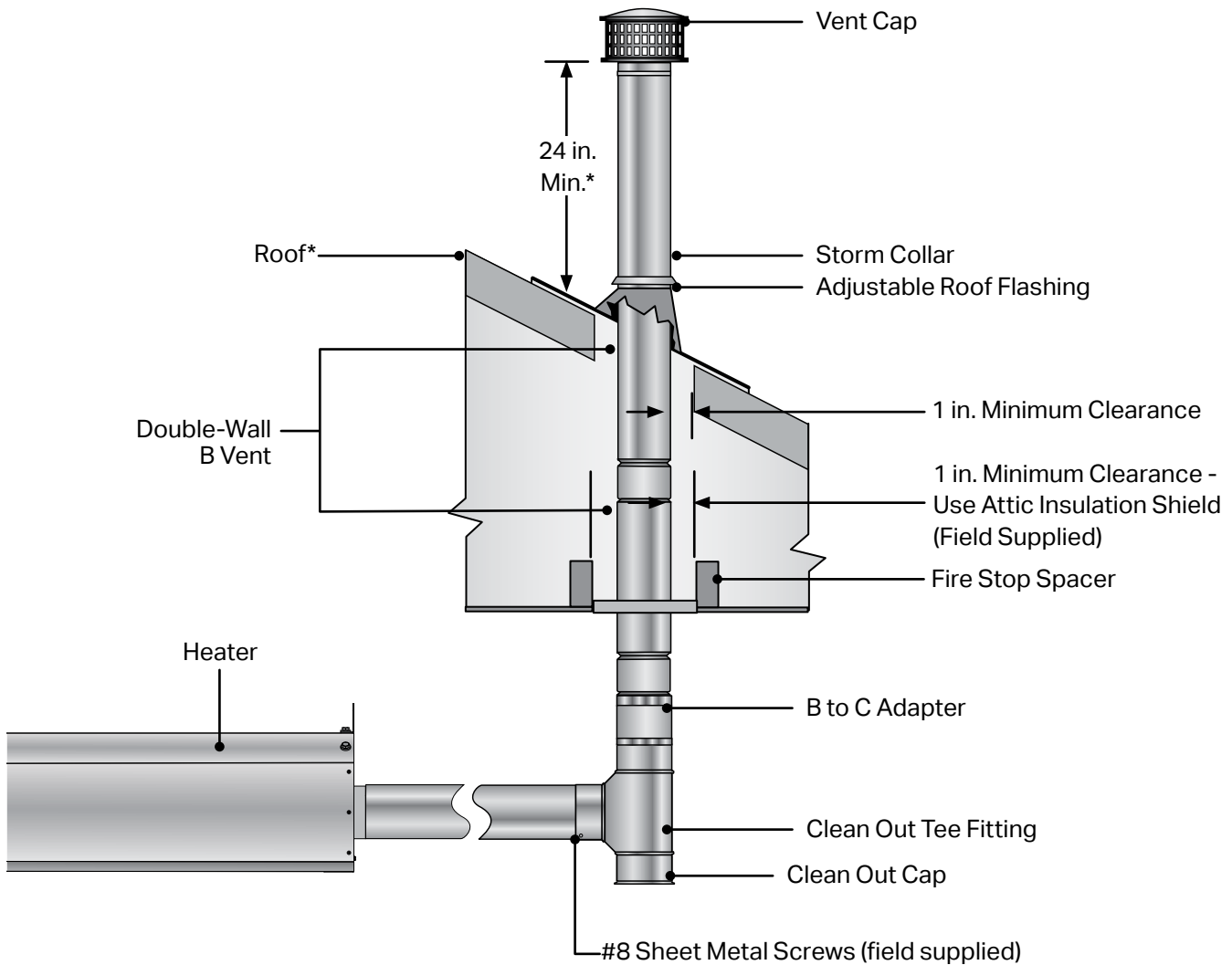

*Consult the NFPA ANSI Z223.1 Gas Vent Termination criteria if roof pitch exceeds 9:12

When possible, avoid venting through an unconditioned space. Venting through an unconditioned space promotes condensation. When venting through an unconditioned space is unavoidable, or if the unit is installed in an area that is prone to condensation, insulate venting runs greater than 5 feet to minimize the production of condensation. Inspect for leakage prior to insulating the venting and only use insulation that is non-combustible with a temperature rating of not less than 480°F. Install a tee fitting at the low point of the vent system and provide a drip leg with a clean out cap as shown in Figure 3.5.

When venting pipe passes through a combustible interior wall or floor, a metal thimble with a diameter 4 inches greater than the vent pipe diameter must be used. If there is 6 feet or more of vent pipe prior to passing through the combustible wall or floor, then the metal thimble need only be 2 inches greater than the vent pipe diameter. If a metal thimble is not used, all clearances to combustibles from the vent pipe must be 6 inches. When permitted, Type-B vent may be used for the last section of vent pipe to reduce the required clearances to combustibles when passing through a combustible wall or floor. When using Type-B vent, follow the manufacturer's recommended clearances to combustibles. Any material used to close or insulate the opening must be non-combustible.

Vertical Venting (Category I) (60,000 BTU/h Models Only)

An appliance that operates with a non-positive vent static pressure and with a vent gas temperature that avoids excessive condensate production in the vent is said to be 'Category I'. The DST series heater is considered a Category I appliance if the venting system meets all of the following criteria:

- The vent system terminates vertically (up).
- The length of the horizontal portion of the vent run is less than 75% of the vertical rise length. (e.g.- If the vertical vent height is 10 feet, the horizontal run is less than 7-1/2 feet).
- The vent terminates a minimum of 5 feet above the vent connection on the unit.
- Horizontal venting sections of the vent pipe must be installed with an upward slope from the appliance at a pitch of 1/4 inch per foot.

For vertical vent termination, the venting must comply with all parts of this section, in addition to the requirements of the general venting.

Category I (Vertical) venting is venting at a non-positive pressure. An appliance vented as a Category I is considered a fan-assisted appliance and the vent system does not have to be 'gas tight'. It is recommended that the venting system is installed with a tee, drip leg, and clean-out cap as shown in Figure 3.6.

Vent Locations and Clearances:

- Separate air intake duct from vent pipe by a minimum of 4 feet by placing vent pipes higher than adjacent air intake ducts.
- Utilize a listed Type-B vent termination cap.
- The vent terminal must extend a minimum of 2 feet above the roof.
- Vent caps should be located a minimum of 2 feet away from adjoining structures.

All vertically vented heaters that are Category I must be connected to a chimney or vent complying with a recognized Standard, or lined masonry (or concrete) chimney with a material acceptable to the authority having jurisdiction. Venting into an unlined masonry chimney is not permitted. Refer to the National Fuel Gas Code and page 15 of this manual.

Use a listed vent terminal to reduce down drafts and moisture in the vent.

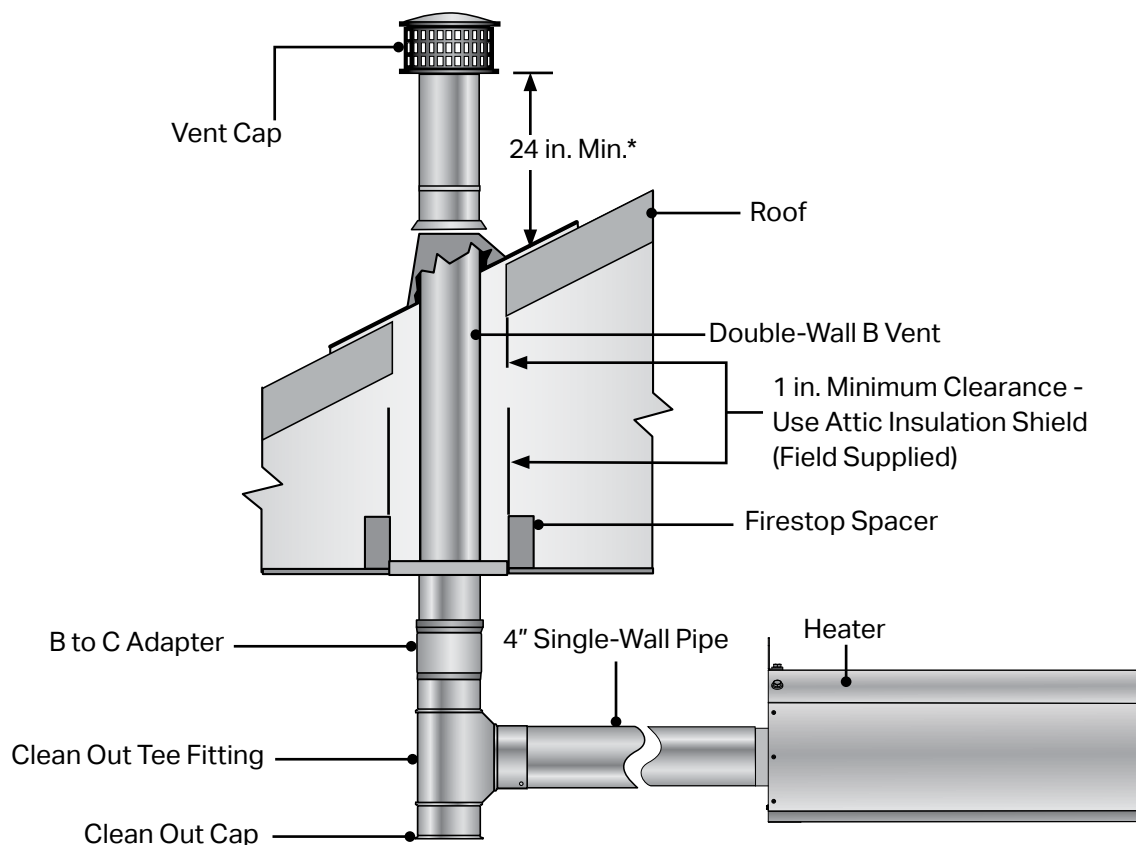
Figure 3.6 • Vertical Venting - Side View

*Consult the NFPA ANSI Z223.1 Gas Vent Termination criteria if roof pitch exceeds 9:12.

Horizontal Venting (Category III) (60,000 BTU/h Models Only)

An appliance that operates with a positive vent static pressure and with a vent gas temperature that avoids excessive condensate production in the vent is said to be "Category III". The DST series heater is considered a Category III appliance if the venting system meets all of the following criteria:

- The vent system terminates horizontally (sideways).
- The vent terminates vertically, but the length of the horizontal portion of the vent run exceeds 75% of the vertical rise length. (e.g.- If the vertical vent height is 10 feet, the horizontal run is greater than 7-1/2 feet).
- The vent terminates below 5 feet of the vent connection on the unit.
- Horizontal venting sections of the vent pipe must be installed with a downward slope from the appliance at a pitch of 1/4 inch per foot.

Seal vent pipes with high temperature sealant and three (3) #8 sheet metal screws. Vent enclosed spaces and buildings according to the guidelines in this manual and applicable national, state, provincial and local codes.

You may either use an agency certified Category III venting system, or single wall vent pipe with all the seams and joints sealed with metallic tape or silicone sealant suitable for temperatures up to 480°F. Wrap the tape two full turns around the vent pipe. For single-wall vent systems, one continuous section of double-wall vent pipe may be used with the vent system to pass through a wall or barrier.

All horizontal Category III vents must be terminated with a Simpson-Duravent sidewall vent cap (P/N: SWD-4).

Vent Locations and Clearances:

- Horizontal venting systems may NOT be common vented, and no other gas units are allowed to be vented into it.
- Vent must terminate a minimum of 4 feet below, 4 feet horizontally from, or 1 foot above any window or door that may be opened or gravity air inlet into the building.
- Vent must terminate a minimum of 3 feet above any forced air inlet that is located within 10 feet.
- The bottom of the vent terminate must be located a minimum of 12 inches above grade level and must extend beyond any combustible overhang. Vents adjacent to public walkways must terminate a minimum of 7 feet above grade level.
- The vent terminal must be installed to prevent blockage by snow and protect building materials from degradation by flue gases.
- The vent cap must be a minimum of 6 inches from the sidewall of the building.
- Vent must be a minimum of 36 inches below or extend beyond any combustible overhang.
- Vents must terminate a minimum of 3 feet from a window or door that may be opened, and a non-mechanical air supply inlet or combustion air inlet into the building.
- Vents must terminate a minimum of 6 feet from a mechanical air supply inlet.

Never join two sections of double wall vent pipe within one horizontal vent system, as it is impossible to verify that inner pipes are completely sealed.

Figure 3.7 • Horizontal Venting Requirements

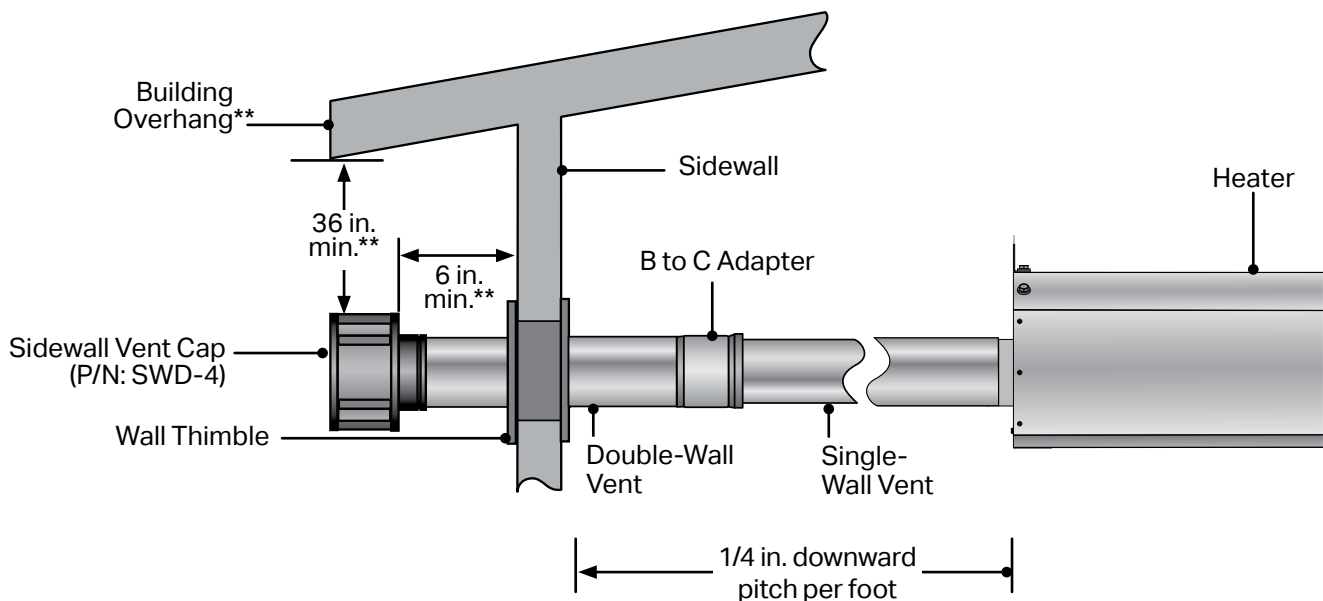

**Vent must extend beyond any combustible overhang if the vent is less than 36 in. below the combustible overhang.

Common Venting (Category I) (60,000 BTU/h Models Only)

The common vent system and all attached appliances must be Category I.

The vent connector should be routed in the most direct route from the units to the common vent.

Where two or more vent connectors enter a common gas vent or chimney flue, the smaller connector shall enter at the highest level consistent with the available head room or clearance to combustible material.

Restrictions within the common vent such as elbows should be minimized. Each elbow installed within the common portion of the vent carrying system reduces the maximum common vent capacity by 10%. Refer to NFPA 54 IFEC tables 11.2 and 11.3 for capacity.

The vent connector capacities allow for the use of two 90° directional changes. For each additional required elbow, the vent connector capacity is reduced by 10%.

The common vent cross sectional area must be equal to or greater than the largest vent connector cross sectional area.

Figure 3.8 • Common Vertical Venting - Side View

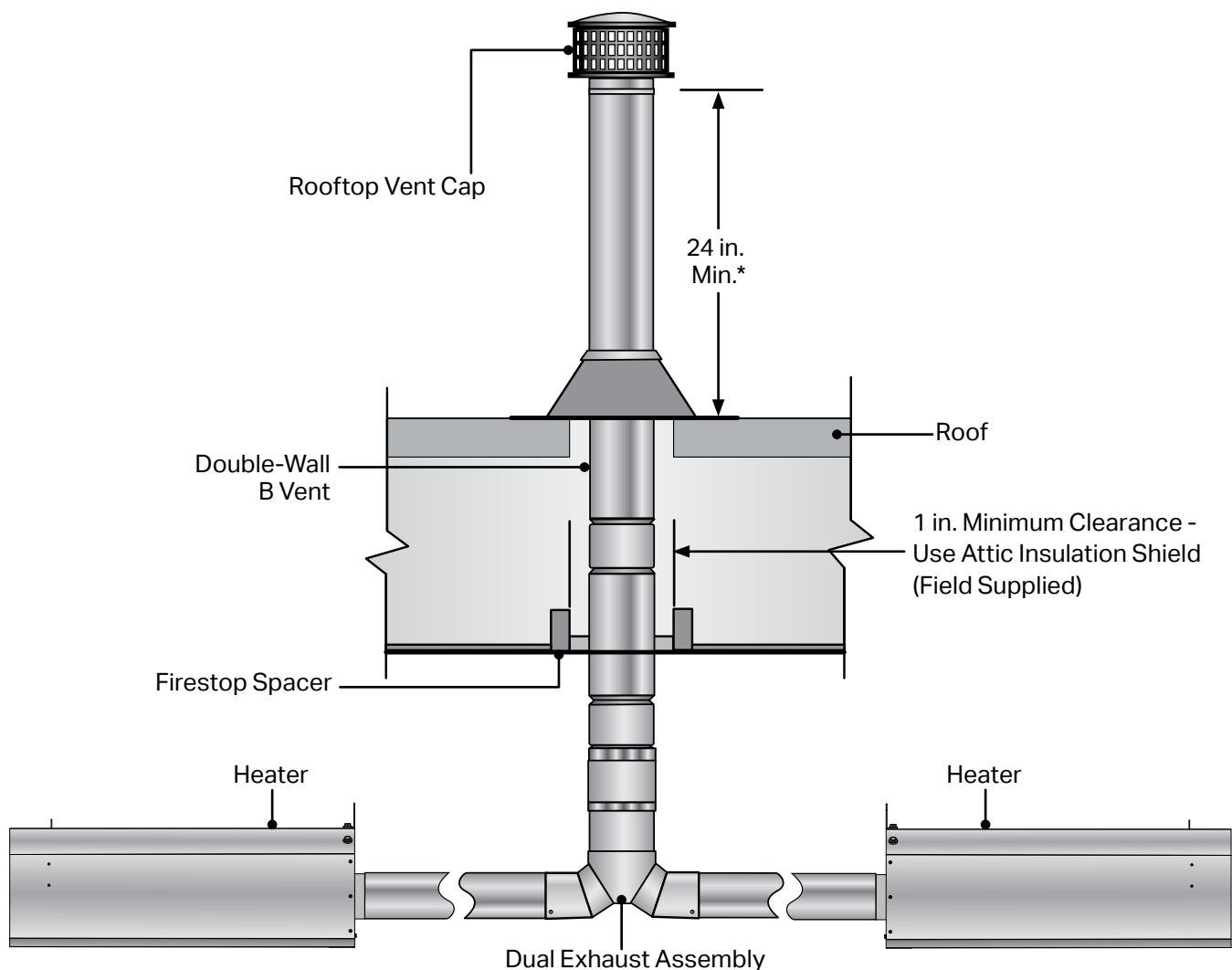

*Consult the NFPA ANSI Z223.1 Gas Vent Termination criteria if roof pitch exceeds 9:12.

Unvented Operation

⚠ WARNING



This appliance must be vented in residential installations. Unvented tube heaters in residential spaces may result in property damage, serious injury, or death. Use unvented operation in commercial and industrial installations with proper ventilation rates only.

When using an unvented configuration in a commercial/industrial application, consider the following:

- A factory vent cap/diffuser (Kit: DST-EXH, included) **must** be used.
- Where unvented heaters are used, natural or mechanical means **must** be provided to supply and exhaust a minimum of 4 cfm/1000 BTU/h input of installed heaters.

NOTE: Gravity or mechanical means may be used to accomplish the air displacement. Local codes may require that the mechanical exhaust system be interlocked with the electrical supply line to the heaters, enabling both to function simultaneously.

- The minimum clearance between the air intake and the exhaust terminal is 4 ft.
- Exhaust openings for removing the flue products must be located above the level of the heater(s).

Figure 3.9 • Minimum End Clearances

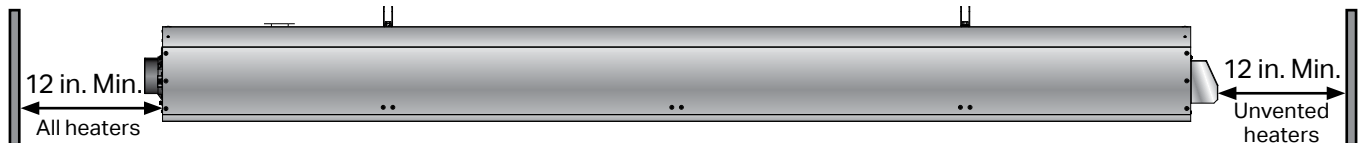

Installation of Exhaust Hood When not Venting Through Roof or Sidewall

NOTE: Applies to all models. DST-80N models are to be un-vented.

- 1 Remove any existing exhaust venting from radiant tube.
- 2 Using a 1/4" nut driver, attach exhaust hood to heater end using screws (4).

Figure 3.10 • Exhaust Hood Installation

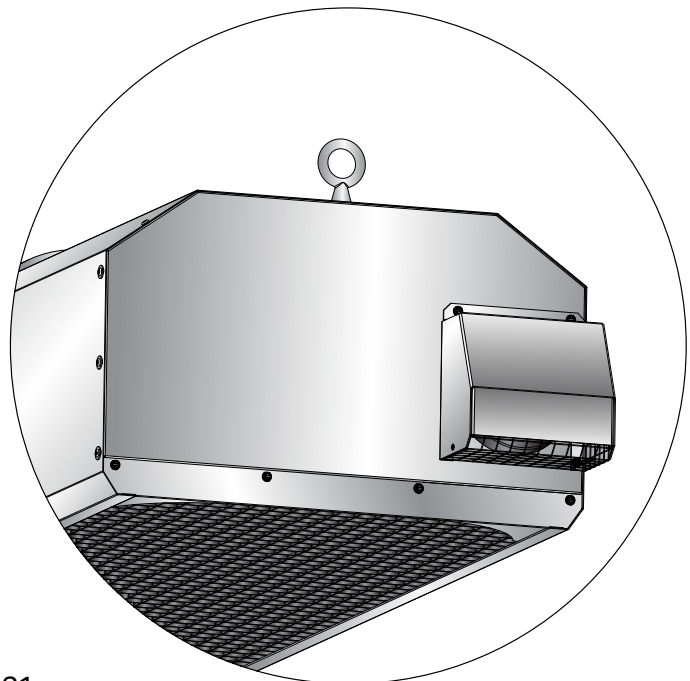

General Combustion Air Requirements *(All Models)*

Combustion air may be supplied to the heater by indoor or outdoor means. Follow these guidelines and all applicable codes for all models prior to installing the combustion air duct work. Local codes may vary. In the absence of local codes, refer and comply with the National Fuel Code ANSI Z223.1 (NFPA 54) latest edition.

This unit comes standard equipped for connection of supplied outdoor air for combustion. It is designed for outside air to be brought into the appliance from combustion intake ducts, and is referred to as a “Separated Combustion” appliance.

WARNING



Sufficient combustion air must be supplied to the appliance at all times. Lack of combustion air may result in property damage, serious injury, or death.

This heater must operate as a separated combustion system if any of the following criteria apply:

- Chemicals such as chlorinated or fluorinated hydrocarbons (typical sources are refrigerants, solvents, adhesives, degreasers, paints, paint removers, lubricants, pesticides, etc.) are present in the atmosphere.
- High humidity.
- Contaminants such as sawdust, welding smoke, etc.
- Negative building pressure.
- Unusually tight construction where the air infiltration rate is less than 0.40 air changes per hour.

If your application does not meet any of these criteria, then room air may be used as supplying combustion air to the heater.

Combustion air may be supplied to the heater by indoor or outdoor means.

If using combustion air from indoors, the required volume of the space must be a minimum of 50 ft³ per 1000 BTU/h unless the building is of unusually tight construction. If the building is of unusually tight construction with air infiltration rates of less than 0.40 air changes per hour, outside combustion air is typically needed unless the sheer size of the building allows otherwise. Contact the factory for further determination of air infiltration rates.

Guidelines:

Chart 3.2 • Limitations for Length and Size of Combustion Air Intake Duct

Single Heater Intake		Dual Heater Intake	
Air Intake Duct Size	Max. Intake Length	Duct Size	Max. Intake Length
4 in.	20 ft.	4 in.(single)/6 in.(dual)	20 ft.
5 in.	30 ft.	4 in.(single)/8 in.(dual)	30 ft.
6 in.	40 ft.	Consult factory for longer intake lengths.	

General

- No more than two 90 degree elbows are allowed.
- Allow for expansion. Use a 4 in. flexible hose to connect the duct to the burner control box.
- In humid environments, use insulated duct, PVC pipe or DWV (drain waste vent) to prevent condensation on the outer surface.
- Do not draw air from attic space.
- A factory approved wall intake cap (P/N: WIV-4) must be used with horizontal outside intake ducts. The wall intake cap (P/N: WIV-4) must be installed to prevent blockage. Locate the intake where dirt, steam, snow, etc. will not contaminate or clog the intake screen.
- Separate air intake duct from vent pipe a minimum of 4 ft. Also, place vent pipe higher than adjacent air intake duct.

Figure 3.11 • Air Intake

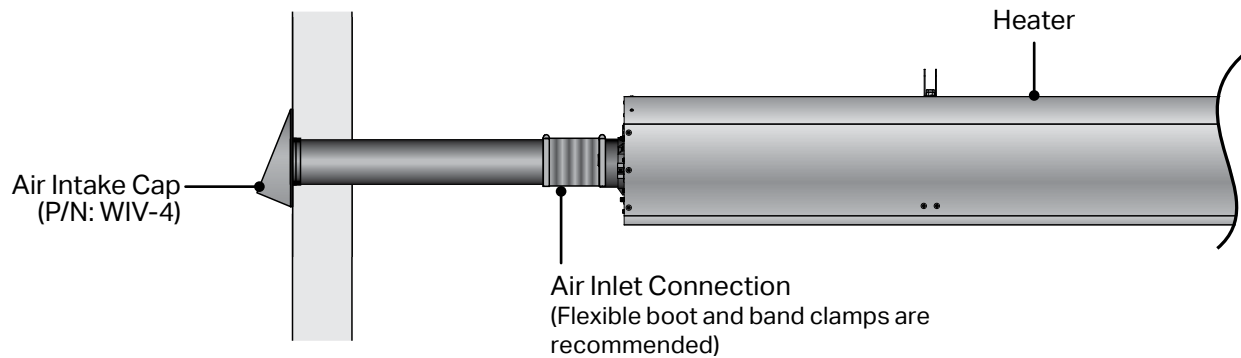

Figure 3.12 • Vertical Combustion Air Intake - Side View

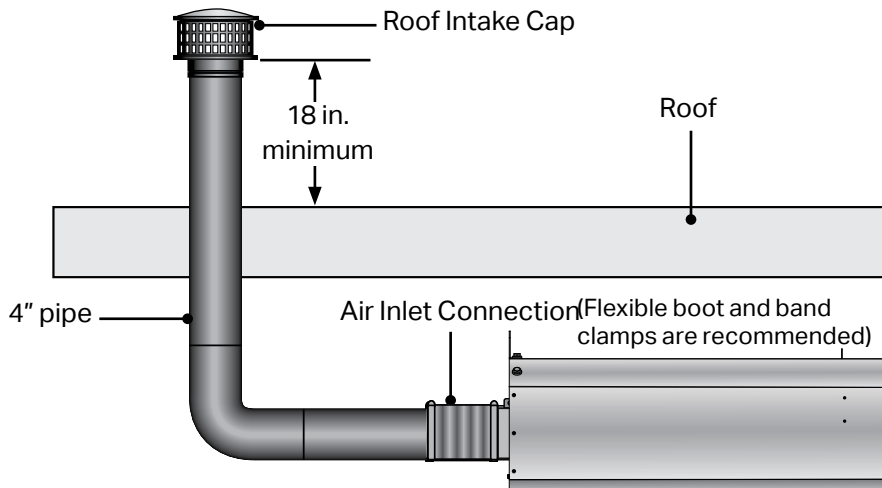

Figure 3.13 • Outside Combustion Air Sidewall Intake - Side View

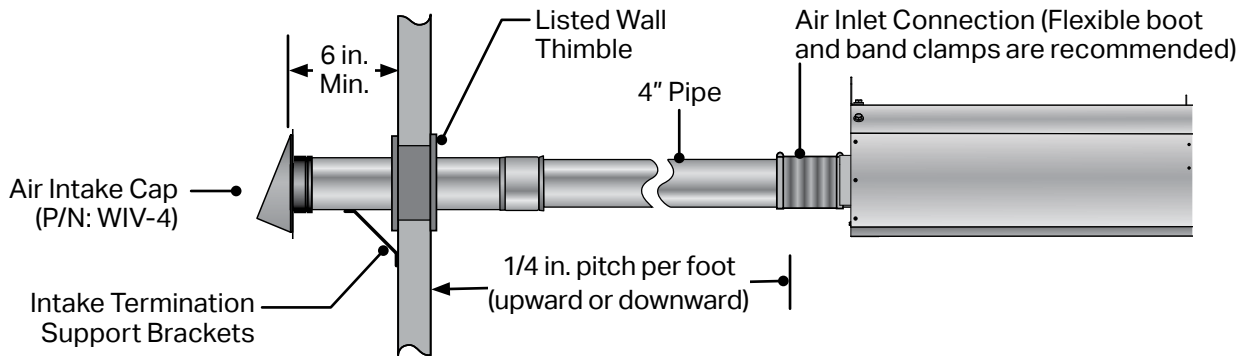
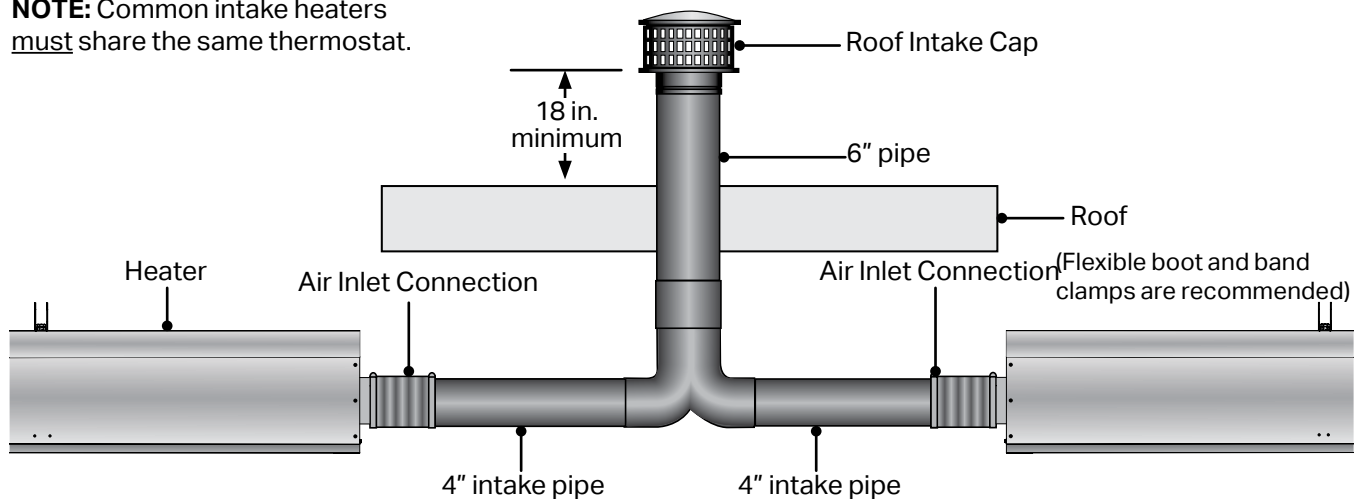

Figure 3.14 • Vertical Outside Air Supply for Common Intake - Side View

NOTE: Common intake heaters must share the same thermostat.



Gas Supply Installation Instructions

The gas supply to the unit heater must be connected and tested in accordance with national, state, provincial, and local codes along with guidelines in this manual. In the United States refer to the latest edition of the ANSI Z223.1 (NFPA54) Standard.

Supply gas piping to the unit should conform with the local and national requirements for type and volume of gas handled, and pressure drop allowed in the line. Avoid pipe sizes smaller than 1/2".

⚠ WARNING



Improperly connected gas lines may result in serious injury and death, explosion, poisonous fumes, toxic gases, or asphyxiation. Connect gas lines in accordance to national, state, provincial, and local codes.

Gas pressure to the appliance controls must never exceed 1/2" PSI (14" W.C.). Damage to the controls may result.

⚠ CAUTION

Gas lines should be purged of air as described in ANSI Z223.1 (NFPA 54) or CSA-B149.1– latest version. Installation of the piping must also conform with the local building codes, or in the absence of local codes, with the latest edition of the National Fuel Gas Code (NFPA 54).

NOTICE

The total input to the appliance must fall within +/- 5% of the rated input as indicated on the rating plate. Otherwise the heat exchanger may prematurely fail.

IMPORTANT! The heating system will expand and contract during operation. **Allowances for expansion must be made between the connection to the heater and the gas supply.** A flexible gas connection of approved type is required. Flexible stainless steel gas connectors installed in one plane, and without sharp bends, kinks, or twists is recommended.

IMPORTANT! Before connecting the gas supply to the burner control box:

- Verify that the heater's gas type (as listed on the rating plate) matches that of your application and the installation complies with national and local codes and requirements of the local gas company.
- Unless otherwise noted on the rating plate, this infrared heater is designed and orificed to operate on standard BTU gas. Contact the factory if utilizing non-standard BTU gas.
- Check that the gas piping and service has the capacity to handle the total gas consumption of all heaters being installed, as well as any other gas appliances being connected to the supply line.
- Check that the main gas supply line is of proper diameter to supply the required fuel pressures.
- If utilizing used pipe, verify that its condition is clean and comparable to a new pipe. Test all gas supply lines in accordance with local codes.

To connect the gas:

WARNING



Failure to install, operate, or service this appliance in the approved manner may result in property damage, injury, or death. Only trained, qualified gas installation and service personnel may install or service this equipment.

The DST series heater is equipped to connect to the corrugated stainless steel tube flexible gas connector (Included). **Do not connect the main gas line directly to the heaters gas inlet without the use of the flexible connector.** All piping must be installed in accordance with the requirements outlined in the National Fuel Gas Code ANSI/Z223.1 (latest edition) or CSA-B149.1. Support all gas piping with pipe hangers, metal strapping, or other suitable material. Do not rely on the heater to support the gas pipe.

WARNING



Always use two (2) opposing wrenches to tighten mating pipe connections to prevent excessive torque on the gas valve and manifold pipe. Excessive torque can damage the valve and/or misalign the orifice, resulting in fire, explosion, serious injury, or death.

When connecting piping to the unit, the use of a thread joint compound is required. The thread compound (pipe dope) shall be resistant to the action of liquefied petroleum gas or any other chemical constituents of the gas to be conducted through piping. Use of Teflon® tape is not permitted.

Connect the main gas supply line with an approved flexible connector or, if the authority having jurisdiction requires rigid piping, the use of approved swing joints may be used. If swing joints are utilized, the heater must be allowed to freely expand and contract without causing undue stress on the gas pipe.

The heater shall not be connected to the building piping system with rigid pipe or semi-rigid metallic tubing, including copper. When using such material, an intermediate connection device that allows for the heater expansion must be used.

The gas outlet must be in the same room as the appliance is installed, and must be accessible. It may not be concealed within or run through any wall, floor, or partition. When installing the heater in a corrosive environment (or near corrosive substances), use a gas connector suitable for the environment. Do not use the gas piping to electrically ground the heater.

Installation of the Gas Line to the Heater

- ❶ Install a sediment trap / drip leg in the supply line at the lowest spot prior to the gas ball valve. The trap length shall be at least three inches long. Ideally, the trap would be installed as close as possible to the shut off. **NOTE:** For high pressure gas above 14" W.C., a high pressure regulator and ball valve must be utilized and located upstream of the flex connector.
- ❷ Install manual shut off ball valve with optional 1/8" NPT Test connection towards the supply line. The manual shut off ball valve must be located within 6 feet of the appliance's service access door.
- ❸ Install the 5/8 inch flare to 1/2" NPT adapter piece downstream of the gas valve as shown in Figures 3.15-3.16. This piece is typically included with the flexible gas connector, loosely installed on one of the flare nuts. **NOTE:** Keep flare surfaces clean and free of sealing compounds. Only the pipe threads require sealing compounds.
- ❹ Form the 1/2" x 24" stainless steel flexible gas connector into a smooth C-shape, allowing approximately 12 inches between the flexible connector's end nuts (see Figure 3.16). The connector must reach from the gas supply to the appliance without stretching, kinking, or twisting.
- ❺ Attach the flexible connector to the 5/8" flare adapter on the gas line and the other end to the 5/8" flare after threading into the valve inlet. **DO NOT** connect the connector flare nuts directly to pipe threads. Use only the adapters provided. **DO NOT** kink, twist, or over-torque the connector when installing.

⚠ CAUTION

When using a stainless steel flexible gas connector, **do not** attach the connector nuts directly to the gas pipe supply. Connector nuts must be installed to an approved adapter.

Figure 3.15 • Gas Connection (Flexible Gas Connection shown)

NOTE: Do not exceed 14 Inches W.C. to the appliance.

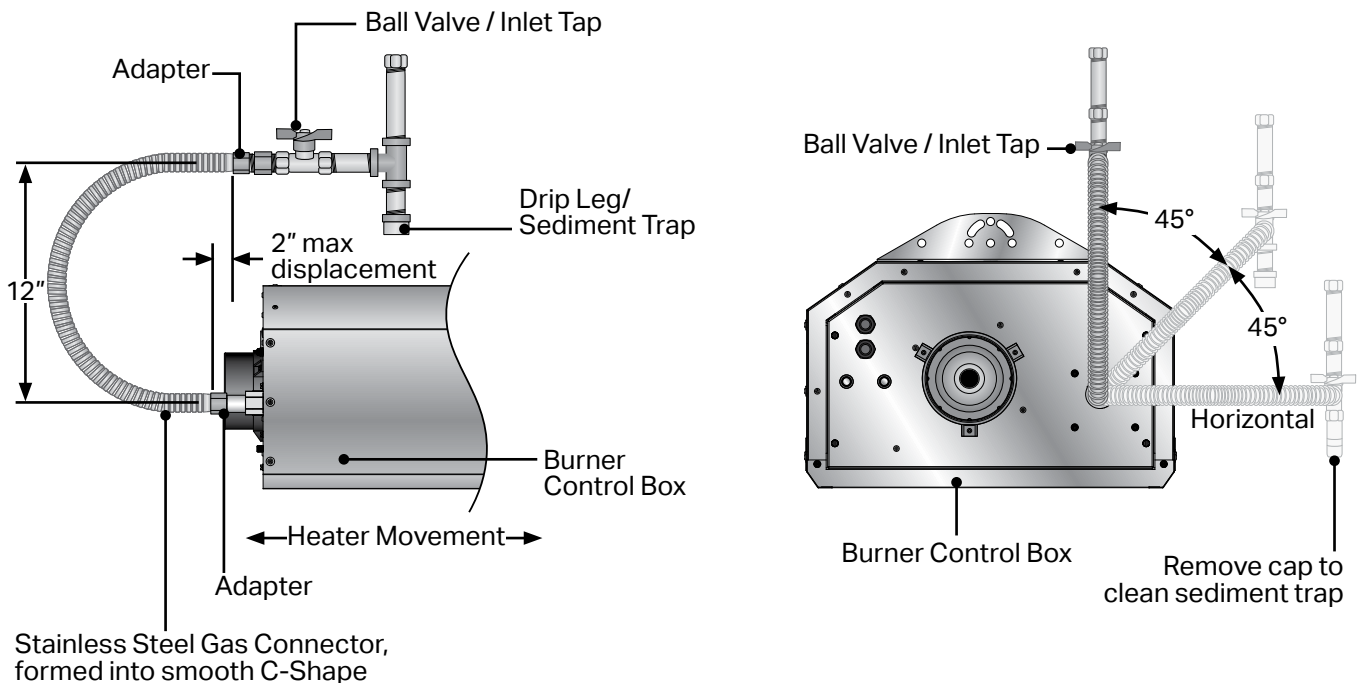

In Canada, infrared heater shall only be connected with a Type I hose connector that is (a) certified as being in compliance with the *Standard for Elastomeric Composite Hose and Hose Couplings for Conducting Propane and Natural Gas, CAN/CGA 8.1*; and (b) of a length of 36 ± 6 in (90 ± 15 cm).

Refer to Chart 3.3 for natural gas and Chart 3.4 for propane to determine the cubic feet per hour (CFH) required for the type of gas and size of unit to be installed. To determine the proper pipe diameter, use the CFH value and the length of pipe necessary from Chart 3.5. In the case where several units are serviced by the same main gas line, the total capacity (CFH) and length of main must be adequate to service all appliances downstream of this main.

Chart 3.3 • Natural Gas Consumption

Model	Input High/Low	Manifold Pressure (Inches W.C.)	Min. Inlet Pressure (Inches W.C.)	Max. Inlet Pressure (Inches W.C.)	Gas Consumption (CFH)*
DST-60	60,000 (High)	3.5	5.0	14.0	57.1
	40,000 (Low)	1.5			38.1
DST-80	80,000 (High)	3.5	5.0	14.0	76.2
	50,000 (Low)	1.5			38.1

* Assumes an average heating value of 1050 BTU/SCF and a Specific Gravity of 0.60.

Chart 3.4 • Propane Gas Consumption

Model	Input High/Low	Manifold Pressure (Inches W.C.)	Min. Inlet Pressure (Inches W.C.)	Max. Inlet Pressure (Inches W.C.)	Gas Consumption (CFH)*	Gallons p/ Hour
DST-60	60,000 (High)	10.0	11.0	14.0	24	.66
	50,000 (Low)	7.1			20	.55

* Assumes an average heating value of 2500 BTU/SCF and a Specific Gravity of 1.53.

Chart 3.5 allows for a 0.3 inch W.C. pressure drop in the supply pressure from the building main to the inlet of the unit. Refer to the chart for the appropriate range of inlet pressures for each gas type. When sizing the inlet gas pipe diameter, make sure that the unit supply pressure can be met after the 0.3 inch W.C. pressure drop has been subtracted from the main pressure. If the 0.3 inch W.C. pressure drop is too high, refer to NFPA 54 or the Gas Engineer's Handbook for other gas pipe capacities.

Install ground joint union with a brass seat and a manual shut-off valve adjacent to the unit for emergency shut-off and easy servicing of controls. A 1/8" NPT plugged tap that is accessible for a test gauge connection is also recommended, as illustrated in Figure 3.16.

A sediment trap must be installed in the supply line in the lowest spot prior to connecting to the heater. The trap length shall be at least three inches long. Ideally, the trap would be installed as close as possible to the shut-off, as shown in Figure 3.16.

Figure 3.16 • Recommended Hardware • Manual Shut Off and Sediment Trap

In Canada, infrared heater shall only be connected with a Type I hose connector that is (a) certified as being in compliance with the *Standard for Elastomeric Composite Hose and Hose Couplings for Conducting Propane and Natural Gas, CAN/CGA 8.1*; and (b) of a length of 36 ± 6 in (90 ± 15 cm).

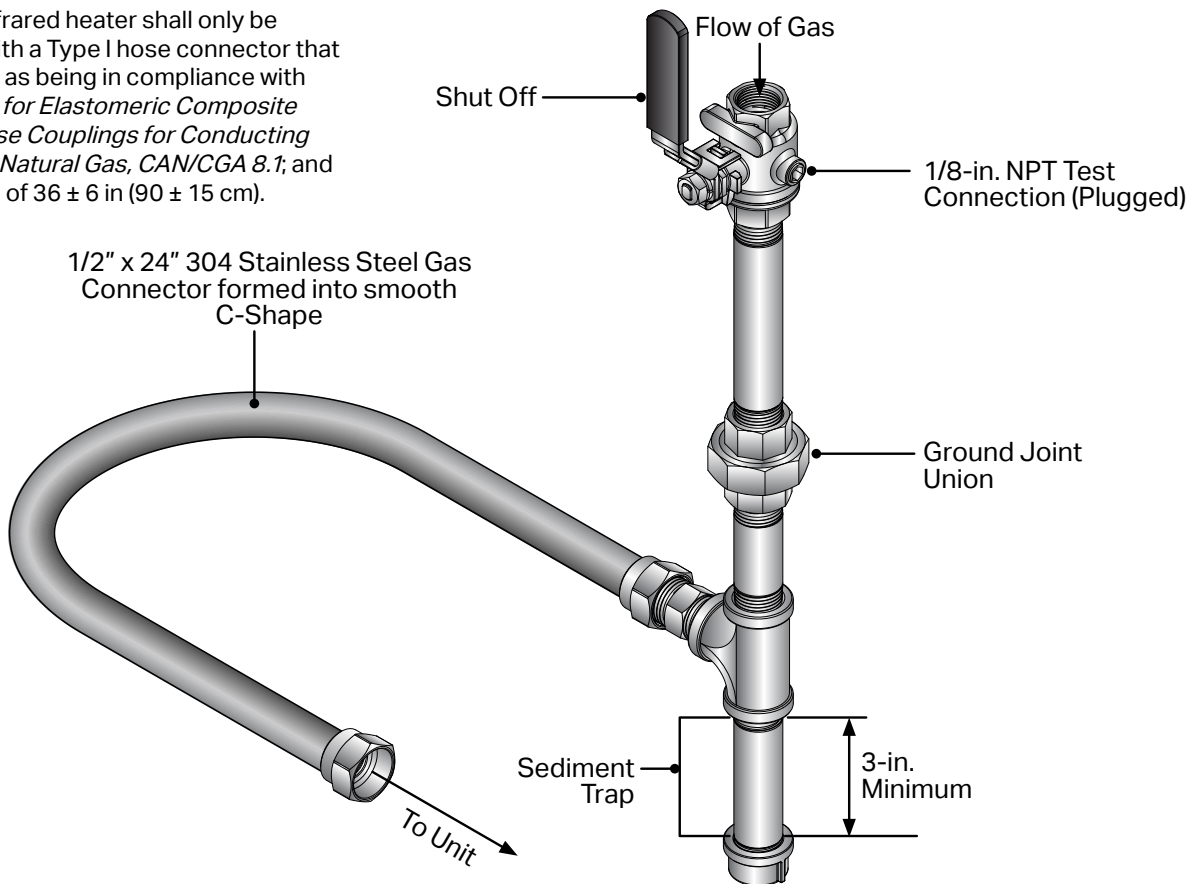

Chart 3.5 • Maximum capacity for Schedule 40 Metallic pipe, in CFH

Pipe Length	1/2"		3/4"		1"		1-1/4"		1-1/2"		2"	
	Nat	Prop	Nat	Prop	Nat	Prop	Nat	Prop	Nat	Prop	Nat	Prop
10 feet	132	86	278	182	520	340	1050	686	1600	1046	3050	1993
20 feet	92	60	190	124	350	229	730	477	1100	719	2100	1373
30 feet	73	48	152	99	285	186	590	386	890	582	1650	1078
40 feet	63	41	130	85	245	160	500	327	760	497	1450	948
50 feet	56	37	115	75	215	141	440	288	670	438	1270	830
60 feet	50	33	105	69	195	127	400	261	610	399	1150	752
70 feet	46	30	96	63	180	118	370	242	560	366	1050	686
80 feet	43	28	90	59	170	111	350	229	530	346	990	647
90 feet	40	26	84	55	160	105	320	209	490	320	930	608
100 feet	38	25	79	52	150	98	305	199	460	301	870	569
125 feet	34	22	72	47	130	85	275	180	410	268	780	510
150 feet	31	20	64	42	120	78	250	163	380	248	710	464
175 feet	28	18	59	39	110	72	225	147	350	229	650	425
200 feet	26	17	55	36	100	65	210	137	320	209	610	399

The DST series heater is equipped to receive a gas supply line nipple of 1/2" NPT Schedule 40 metallic pipe. All piping must be installed in accordance with the requirements outlined in the National Fuel Gas Code ANSI/Z223.1 (latest edition) or CSA-B149.1. Support all gas supply piping with pipe hangers, metal strapping, or other suitable material. Do not rely on the heater to support the gas pipe.

When connecting piping to the unit, the use of a thread joint compound is required. The thread compound (pipe dope) shall be resistant to the action of liquefied petroleum gas or any other chemical constituents of the gas to be conducted through the piping. Use of Teflon® tape is not permitted.

⚠ WARNING



Always use two (2) opposing wrenches to tighten mating pipe connections to prevent excessive torque on the gas valve and manifold pipe. Excessive torque can damage the valve and/or misalign the orifice, resulting in fire, explosion, serious injury, or death.

Leak Testing

⚠ WARNING



Testing for gas leaks with an open flame or other sources of ignition may lead to a fire or explosion and cause serious injury, or death. Test in accordance with NFPA or local codes.

⚠ WARNING



Gas pressures to the appliance controls must never exceed 14 inches W.C. (1/2 PSI). Supply pressures greater than 14" W.C. can damage the controls, resulting in personal injury, property damage, or death.

Use a soap solution or equivalent for leak testing. Leak testing solution must be non-corrosive, and be rinsed off immediately after the leak test. Never test for leak with an open flame. Failure to comply could result in personal injury, property damage, or death.

Always leak test final gas assembly for gas leaks according to the procedures outlined in NFPA 54 and all local codes and/or Standards.

For leak testing on pressures below 1/2 PSI

Before leak testing, close the field installed manual shut off valve shown on Figure 3.25 on the supply line to isolate the gas valve from the pressure. **NOTE:** All factory installed gas connections have passed an approved leak test.

For leak testing on pressures above 1/2 PSI

When leak testing with pressures above 1/2 PSI (14 inches W.C.), the unit must be isolated from the supply pipe. Close the field installed manual shut off valve, disconnect the supply line to the unit, and temporarily cap the supply line for testing purposes.

Electrical Requirements and Wiring Diagrams

⚠ WARNING



Shock hazard. Disconnect power supply before making wiring connections to prevent electrical shock and equipment damage.

Any original factory wiring that requires replacement must be replaced with wiring material having a temperature rating of at least 105°C minimum voltage.

All field installed wiring to the tube heater must be done in accordance with the national, state, provincial, local codes, and to the guidelines in this manual. In the United States, refer to the most current revisions to the Electrical Code ANSI/NFPA 70. The unit must be electrically grounded according to these codes. Line polarity must be observed when making field connections.

Internal Wiring Diagrams

Before wiring this appliance, check the existing wiring; replace if necessary. If any of the original wire supplied with the appliance must be replaced, it must be replaced with copper wiring material having a rating of at least 600V, 105°C.

Figure 3.17 • Internal Wiring Diagram

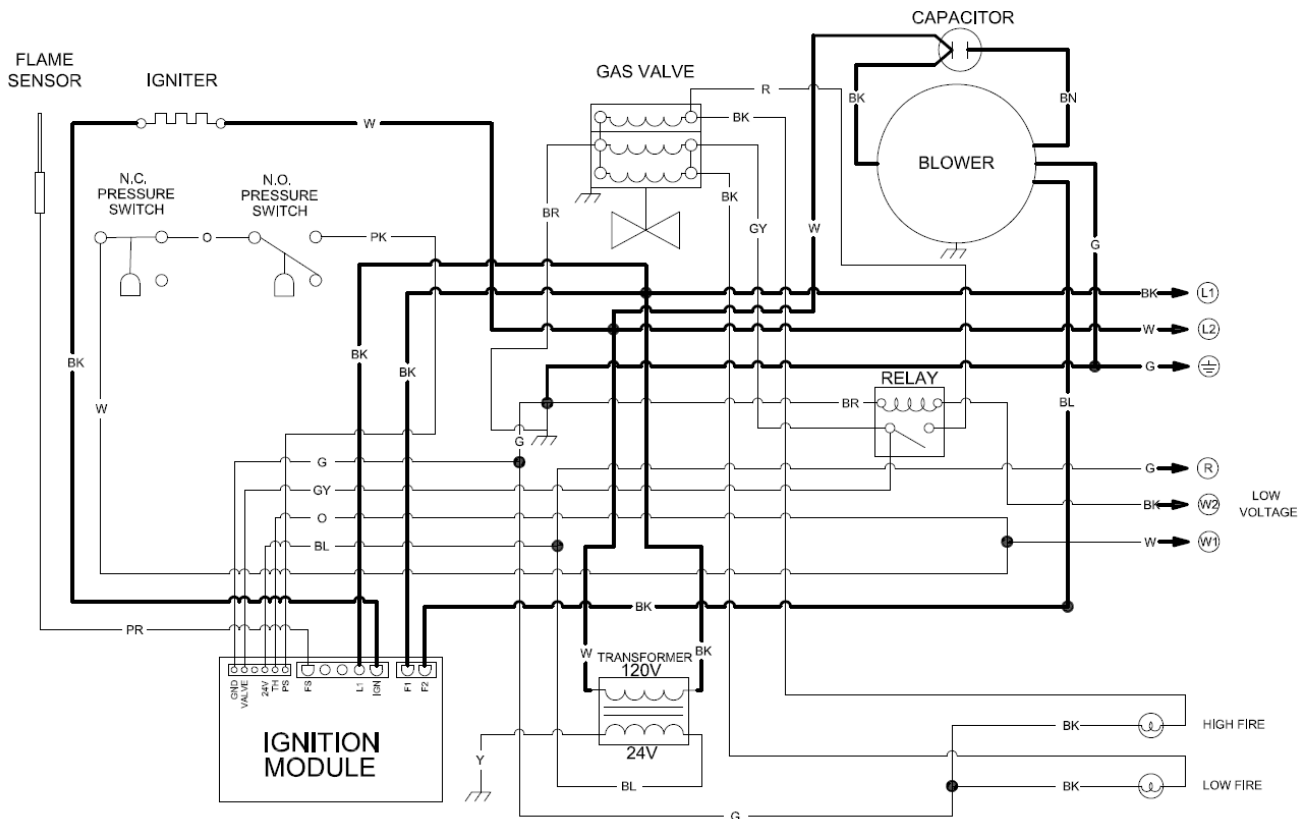

WIRING INFORMATION:

LINE VOLTAGE:

- FACTORY STANDARD —————
- FACTORY OPTION - - - - -
- FIELD INSTALLED - - - - -

LOW VOLTAGE:

- FACTORY STANDARD —————
- FACTORY OPTION - - - - -
- FIELD INSTALLED - - - - -

Electrical Requirements

⚠ WARNING



Incorrect or improper wiring may result in shock, injury, or death. Field wiring to the heater must be connected and grounded in accordance with national, state, provincial, local codes, and to the guidelines in this manual. Refer to the most current revisions to the ANSI/NFPA 70 Standard.

All field wiring to the DST series heater must be done in accordance with the national, state, provincial, local codes, and the guidelines in this manual. In the United States, refer to the most current revisions to the Electrical Code ANSI/NFPA 70. The unit must be electrically grounded according to these codes.

Field Wiring Supply Voltage

Before proceeding with electrical connections, ensure that the supply voltage, frequency, phase, and current capacity meet the requirements specified on the rating plate. A dedicated line voltage supply with properly sized wire should run directly from the main electrical panel to the heater. The power to the unit must be protected with a circuit breaker appropriate for the load. The unit must be electrically grounded in accordance with local codes, or in their absence, with the latest edition of the National Electrical Code, ANSI / NFPA 70 and/or the Canadian Electrical Code CSA C22.1, latest edition.

⚠ CAUTION

The power supply to the heater must be within +/- 5% of the voltage rating as indicated on the rating plate of the appliance. If input power does not meet these specifications, contact your utility company.

The heater comes equipped with a supply cord to connect the main power supply. It is located at the rear of the heater's burner box, and utilizes a grounding prong. This plug must be connected into an appropriate outlet receptacle that is properly installed and grounded in accordance to local codes and ordinances.

The grounding receptacle must be installed within 5 feet of the heater's service panel, and located in the space occupied by the appliance. When plugging in the heater, make sure the supply cord is protected from damage, and keep all cords away from the heater's surfaces and out of the clearances to combustibles zones (see page 9). When routing the electrical supply for the unit, ensure that it does not interfere or obstruct the heater's service panel. Keep any electrical supply cord away from any heated surfaces.

⚠ WARNING



Electric Shock Hazard

Do not force the three-prong plug into the grounded outlet, modify the plug, or use an adapter. Never operate this appliance if the cord or plug is damaged.

Thermostat Connection

NOTE: Different thermostats operate according to their particular features. Refer to the thermostat’s specifications for details.

Prior to connecting the thermostat wire to the heater, check to make sure the wires will be long enough to allow for the heater to freely expand and contract without causing undue strain on the wires or terminal. Use 18 gauge wire (or larger) that is suitable for a NEC Class 2 rating for thermostat connections.

Each DST series heater may be controlled by a thermostat or switch. The control voltage is 24 VAC and the burner control box is equipped with a 60" yellow 24 VAC control wire. Do not supply 120 VAC to the 24 VAC connection.

Controls Operation

This heater is designed for use in an outdoor environment. Therefore, controlling the heater by use of a thermostat may not be the best means of temperature control. In an outdoor application, the air temperature may not increase and never satisfy the thermostat. The preferred control device when operating this heater in an outdoor area is a switching or timer device.

In an application where there are several wind breaks or a partially enclosed area, a thermostat can be used.

Figure 3.18 • Field Wiring Diagram - Controlling a single heater with a single control device

Starting Amp Draw: 5.2 Amps

Running Amp Draw: 0.7 Amps

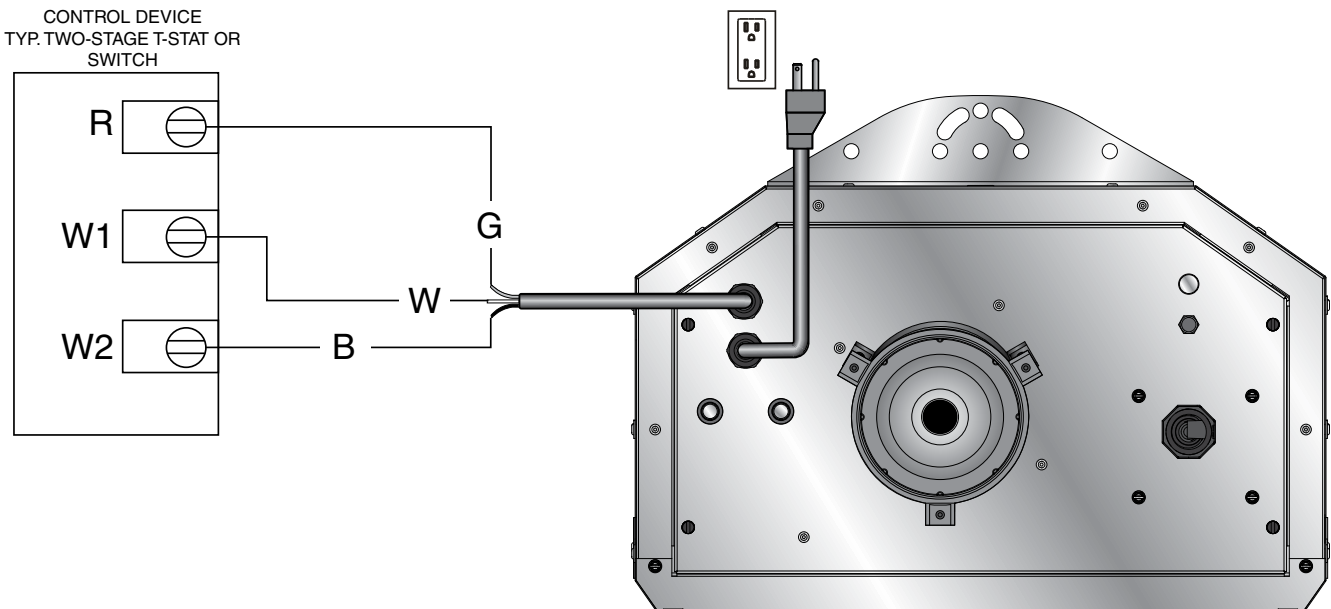
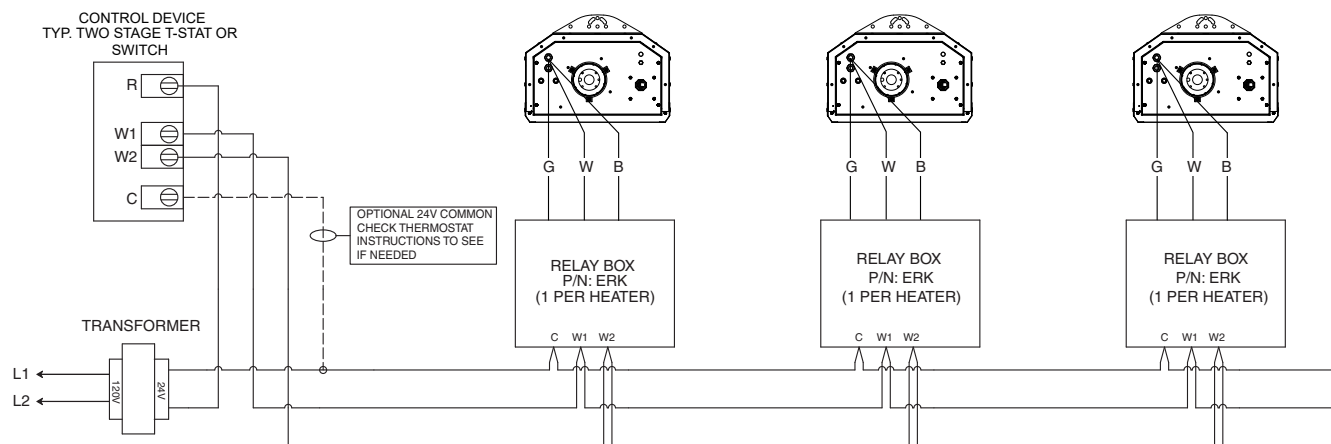

Figure 3.19 • Field Wiring Diagram - Controlling multiple heaters with a single control device**Starting Amp Draw:** 5.2 Amps**Running Amp Draw:** 0.7 Amps**Field Wiring:**

- ❶ 24 VAC/20 VA transformer (.8 Amp) per heater is required (supplied by installer).
- ❷ Maintain electrical polarity when hooking up multiple heaters.
- ❸ Allow heaters to be switched by zones for heating flexibility.
- ❹ Do not attempt to install transformer inside of heater.

Unit Start-up (Commissioning)**⚠ WARNING**

Improper installation, adjustment, alteration, service, or maintenance can cause property damage, serious injury, or death. This heater must be installed and serviced by a trained gas installation and service personnel only.

⚠ CAUTION**Shock Hazard.**

Before attempting to perform any service or maintenance, turn electrical power to unit **OFF** at disconnect switch.

Pre-Start Up Checks

Verify that the installation conforms to all of the specifications of the manual, as well as with local, state, national, and provincial codes. In absence of local codes, the unit heater must be installed according to the current National Fuel Gas Code ANSI Z223.1 (NFPA 54).

Prior to starting up the unit, verify that:

- ✓ The gas type listed on the rating label matches that of your application.
- ✓ The gas connections have been purged of air and properly leak tested.

- ✓ The voltage type and frequency listed on the rating label matches that of your application.
- ✓ The unit is properly grounded as per the National Electrical Code, ANSI/NFPA 70 or Canadian Electrical code CSA C22.1 Part 1.
- ✓ The unit is properly mounted to a permanent structure able to bear the weight of the unit.
- ✓ The proper mounting height is observed for the application.
- ✓ All clearance to combustibles distances or service clearances are maintained.
- ✓ The unit is properly isolated or installed to prevent excessive vibration.
- ✓ The unit is level horizontally.
- ✓ Venting is properly installed in accordance with this manual and any applicable codes.
- ✓ Combustion air supply is sufficient to support proper operation at all times.

Verify Proper Inlet Pressure

Before starting up the unit, smell all around the unit heater for gas. Be sure to smell next to the floor because some gas is heavier than air and will settle on the floor.

When turning the gas shut off valve, only use your hand. Never use tools to turn the knobs, as it may damage the valve resulting in a fire or explosion. If the knob is stuck, do not try to repair it. Contact a qualified service technician or your local gas company.

To verify the proper inlet pressures, follow the following steps:

- ❶ Turn off the gas supply at the manual gas shut off valve.
- ❷ Remove module end panel by removing the four (4) thumb screws. To remove completely, the Glo-Bar igniter, sensor wire, and pressure switch hose have to be disconnected.
- ❸ Remove the service port door from the end panel.
- ❹ Remove the inlet pressure tap plug on the gas control valve (see Figure 3.20).
- ❺ Connect pressure gauge tube and manometer. Run the hose from the valve through the service port.
- ❻ Reinstall the module end panel, making sure to reconnect the Glo-Bar hose and wires, and sensor wires.
- ❼ Turn on the gas supply at the manual gas shut off valve.
- ❽ Turn on the electrical power to the heater.
- ❾ To light the main burners, set the room thermostat to a point above room temperature.

NOTE: This heater is equipped with an ignition device, which automatically lights the burner. This heater cannot be lighted manually. Do not try to light the burner by hand.

Verify *minimum* inlet gas supply pressure:

- ❿ Turn on all other gas appliances that are on the same supply line. If the other gas appliances have multiple inputs, set it to the maximum rating.

- 11 Observe the pressure rating on the pressure gauge.

The minimum inlet gas supply pressure for:

- Natural gas is 5.0 inches W.C.
- Propane gas is 11.0 inches W.C.

Verify *maximum* inlet gas supply pressure:

- 12 Turn off all other gas appliances on the same supply line.

- 13 Observe the pressure reading on the pressure gauge.

The maximum inlet gas supply pressure for:

- Natural gas is 14.0 inches W.C.
- Propane gas is 14.0 inches W.C.

IMPORTANT: If the inlet gas supply pressure is not within the minimum and maximum range as shown on the rating plate, contact your gas supplier.

Removing pressure gauge from inlet port on gas valve.

Set thermostat or other control device to the lowest set point.

- 14 After heater has completed the post-purge cycle, turn off the electrical power to the heater.
- 15 Turn off the gas supply at the manual gas shut off valve.
- 16 Remove module end panel by removing the four (4) thumb screws. To remove completely, the Glo-Bar igniter, sensor wire, and pressure switch hose have to be disconnected.
- 17 Remove pressure gauge tube from inlet pressure tap. Replace the inlet pressure tap plug along with the service port plug.
- 18 Reinstall the module end panel, making sure to reconnect any disconnected wires and hoses.
- 19 Leak check the re-installed pressure tap plug using a soap solution or equivalent method as described in ANSI Z223.1 (NFPA 54).

Verify Manifold Pressure

Before starting up the unit, smell all around the heater for gas. Be sure to smell next to the floor because some gas is heavier than air and will settle on the floor.

When turning the gas shut off valve, only use your hand. Never use tools to turn the knobs, as it may damage the valve resulting in a fire or explosion. If the knob is stuck, do not try to repair it. Contact a qualified service technician or your local gas company.

To verify the proper manifold pressure, follow the following steps:

- 1 Turn off the gas supply at the manual gas shut off valve.
- 2 Remove module end panel by removing the four (4) thumb screws. To remove completely, the Glo-Bar igniter, sensor wire, and pressure switch hose have to be disconnected.
- 3 Remove the service port door from the end panel.
- 4 Remove the manifold pressure tap plug on the gas control valve.
- 5 Connect the pressure gauge tube and manometer.
- 6 Reinstall the module end panel, making sure to reconnect the Glo-Bar hose and wires, and sensor wires.

- 7 Turn on the gas supply at the manual gas shut off valve.
- 8 Turn on the electrical power to the heater.
- 9 To light the main burners, set the room thermostat to a point above room temperature.

NOTE: This heater is equipped with an ignition device, which automatically lights the burner. This heater cannot be lighted manually. Do not try to light the burner by hand.

Verify manifold pressure:

- 10 After the unit has successfully ignited, wait five minutes prior to taking any readings. The heater must be in a steady state of operation prior to taking a manifold pressure reading.
- 11 While waiting for the unit to stabilize, observe the characteristics of the flame. The flame should be stable and should not lift from the burner. The burner color should be light blue, and not create excessive noise.
- 12 After five minutes, observe the pressure rating on the pressure gauge.

The target manifold gas supply pressure for:

- Natural gas is 3.5 inches W.C.
- Propane gas is 10.0 inches W.C.

NOTE: Manifold pressure of the heater is pre-set at the factory. No adjustment should be necessary.

During the verification process, a tolerance of +/- 5% of the full scale is acceptable due to varying atmospheric conditions. If manifold pressure is outside of this tolerance, then an adjustment may be necessary.

Removing Pressure Gauge from Manifold Port on Gas Valve:

- 13 Set thermostat or other control device to the lowest set point.
- 14 After heater has completed the post-purge cycle, turn off the electrical power to the unit heater.
- 15 Remove module end panel by removing the four (4) thumb screws. To remove completely, the Glo-Bar igniter, sensor wire, and pressure switch hose have to be disconnected.
- 16 Turn off the gas valve with the switch located on the valve body.
- 17 Remove the pressure gauge tube and the manometer.
- 18 Replace the manifold pressure tap plug on the gas control valve and service port plug. Reinstall the module end panel, making sure to reconnect any disconnected wired and hoses.
- 19 Leak check the re-installed pressure tap plug using a soap solution or equivalent method as described in ANSI Z223.1 (NFPA 54).

Figure 3.20 • Gas Valve Shown in OFF Position

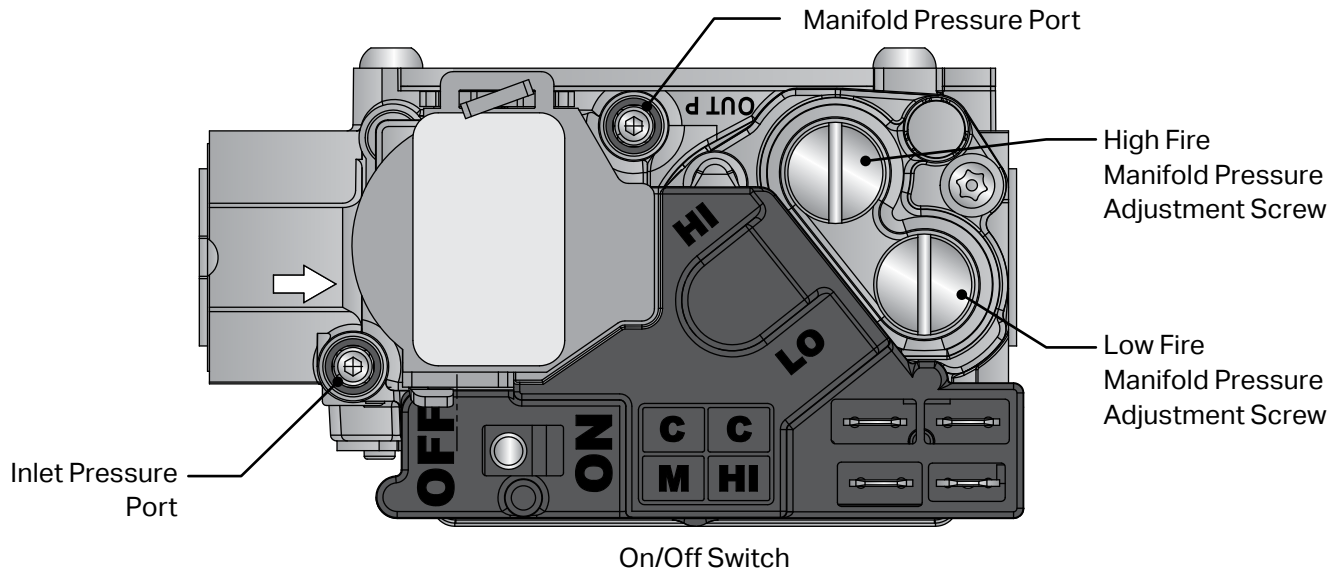

Prior to Leaving the Job Site

Prior to leaving the job site, verify that:

- ✓ The heater is clear of any objects that would interfere with the proper air circulation or that violate the listed clearances to combustibles.
- ✓ Manual gas shut off is ON.
- ✓ Electrical power is ON.
- ✓ Thermostat is set to desired temperature.
- ✓ Properly dispose of all packaging materials.
- ✓ Check to be sure you have all of your tools.
- ✓ Leave the Installation, Operation, Maintenance, and Parts Manual with the owner or end user.

! WARNING



Explosion hazard. This heater must be converted by a trained gas installation and service personnel only. Failure to comply could result in personal injury, asphyxiation, death, fire, or property damage.

4.0 Operation

⚠ WARNING



This appliance does not have a pilot ignition. It is equipped with an ignition device which automatically lights the burner. Do not attempt to light the system by hand.

Operating Instructions

⚠ WARNING





Use only your hand to turn the manual shut off. Never use tools. If the knob will not turn by hand, don't try to repair it; call a qualified technician. Force or attempted repair may result in a fire or explosion.

BEFORE OPERATING, smell all around the appliance area for gas. Be sure to smell next to the floor because some gas is heavier than air and will settle to the floor. Refer to page 1 "If you smell gas" and on safety label affixed to the heater.

DO NOT use this appliance if any part has been under water. Immediately call a qualified service technician to inspect the appliance and to replace any part of the control system and any gas control which has been under water.

Lighting Procedures:

- ① **STOP!** Read the safety information in the manual prior to proceeding.
- ② Set the thermostat to the lowest setting.
- ③ Turn OFF all electrical power to the appliance.
- ④ Turn manual shutoff clockwise  to "OFF". See Figure 3.19.
- ⑤ Wait five (5) minutes to clear out any gas. If you smell gas STOP! Follow the safety information found on page 1 "If you smell gas" and on safety label affixed to the heater. If you do not smell gas, proceed to step 6.
- ⑥ Turn manual shutoff knob counterclockwise  to "ON".
- ⑦ Turn "ON" all electrical power to the appliance.
- ⑧ Set thermostat to desired setting.
- ⑨ If the appliance will not operate, follow instructions below to turn "OFF" gas to the appliance and call your service technician or gas supplier.

Shutdown Procedures:

- ① Set the thermostat to the lowest setting.
- ② Turn OFF all electrical power to the appliance if service is to be performed.
- ③ Turn manual shutoff knob clockwise  to "OFF". See Figure 3.19. **Do not** force.

If the heater's internal diagnostic LED displays any of the signals listed in Charts 4.1-4.2, address the indicated problem as outlined.

⚠ WARNING



This heater must be installed and serviced by trained gas installation and service personnel only.

Do not bypass any safety features or the heater's built in safety mechanisms will be compromised.

Sequence of Operation

Standby: The ignition module (circuit board) continually checks for internal faults, circuit integrity and relay contact positioning.

Starting Circuit: Upon a call for heat, the control verifies that the burner and exhaust pressure switches are in their proper positions. The control energizes the fan. Once operational static pressure is achieved, the burner pressure switch will close initiating the ignition sequence. The hot surface igniter is powered and the gas valve opens after 45 seconds. If the flame is not sensed, the heater will attempt to re-ignite for a total of 3 trials for ignition before proceeding to soft lockout.

Low Fire Running Circuit: After ignition, the flame rod monitors burner flame. If sense of flame is lost, the control closes the gas valve within one second and a new trial sequence (identical to the starting sequence) is initiated. If flame sense is not established within 8.5 seconds, the heater will attempt two additional ignition sequences before proceeding to soft lockout. The control can be reset by briefly interrupting the power source.

High Fire Running Circuit: The second stage on the gas valve is powered directly from the second stage of the thermostat. In order for high fire to engage, low fire must be energized as well. The thermostat determines which stage to maintain for the desired comfort level.

Shut Down: When the thermostat is satisfied, the fan will enter a two (2) minute post-purge cycle.

Diagnostics

Lockout:

The controls will automatically lockout the heater system when an external or system fault occurs. There are two types of lockout:

Soft Lockout: The heater will attempt to light three times. In the event of a failed attempt to light, (gas pressure, valve, no flame sense etc.), the heater will enter a soft lockout period for 30 minutes and then attempt to light three more times before entering hard lockout mode.

Hard Lockout: If proof of flame is not established, a component failure occurs or blockages are evident, the heater will enter a hard lockout. If lockout occurs, the control can be reset by briefly interrupting the power source. Refer to Chart 4.1 for a description of LED codes.

Internally located operational indicator lights are provided to assist in troubleshooting of the heater. Refer to pages 44-47 for additional troubleshooting.

Shutdown Procedures:

- ❶ Set the thermostat to the lowest setting.
- ❷ Turn OFF all electrical power to the appliance if service is to be performed.
- ❸ Turn manual shutoff knob clockwise  to "OFF". See Figure 3.17. **Do not** force.

If the heater's internal diagnostic LED displays any of the signals listed in Chart 4.1, addresses the indicated problem as outlined.

Chart 4.1 • LED Diagnostic Codes - Capable Controls Board

LED CODE	FAULT STATUS	FAULT CODE DELAY*
Initial flash (Red) on power up	Normal operation	Immediate
Steady flash (Green) during Ignition	Normal operation	Immediate
Steady on (Green) after flame sense.	Normal operation	1 minute
1 flash (Red)	Ignition failure	3 minutes
2 flashes (Red)	Ignitor error	12 seconds
3 flashes (Red)	Gas valve error	
4 flashes (Red)	Line voltage frq. error	
5 flashes (Red)	Internal control error	
6 flashes (Red)	Pressure switch error	

*Some LED codes have a time delay before the LED will flash.

Chart 4.2 • LED Diagnostic Codes - Fenwal Circuit Board

LED CODE	FAULT STATUS	FAULT CODE DELAY*
Initial flash on power up, then steady off	Normal operation	Immediate
Steady on	Module failure/Internal fault	Immediate
1 flash	Ignition failure	32 minutes
1 flash	Reverse Polarity	30 seconds
2 flashes	APS 1 failure	12 minutes
3 flashes	APS 2 failure	22 minutes
4 flashes	Solenoid valve fault/Leaky valve/Flame amplifier fault	Immediate
No flash on 117V start-up	Transformer fault	Immediate

*Some LED codes have a time delay before the LED will flash.

5.0 Maintenance

⚠ WARNING



Personal injury or death may result if maintenance is not performed by properly trained gas installer or service personnel. Contact the installing distributor or place of purchase for service. **Do not operate heating system if repairs are necessary.**



Allow heater to cool prior to servicing.

Disconnect power to heater before servicing.

Use protective glasses when maintaining the heater.

Routine Maintenance and Inspection

At least once per year, the heating system should be inspected and serviced by trained gas installation and service personnel only. This inspection should be performed at the beginning of the heating season to insure that all heater components are in proper working order and that the heating system operates at peak performance. Particular attention should be paid to the following items.

- **Clearances to Combustibles:** Inspect the area near the unit to be sure there is no combustible material located within the minimum clearance requirements listed in this manual. Under no circumstances should combustible material be located within the clearances specified in this manual. Failure to provide proper clearance could result in personal injury or equipment damage from fire.
- **Gas Connection:** Inspect the integrity of the gas connection to the heater. Check for leaks, damage, fatigue or corrosion. Do not operate if repairs are necessary and turn off gas supply to the heater. Contact service personnel.

To check gas tightness of the safety shut-off valves, turn off the manual valve upstream of the appliance combination control. Remove the hex head plug on the inlet side of the combination control and connect a manometer to that tapping.

Turn the manual valve on the apply pressure to the combination control. Note the pressure reading on the manometer, then turn the valve off. Any loss of pressure indicates a leak. If leak is detected, use a soap solution to check all threaded connection. If no leak is found, combination control is faulty and must be replaced before putting appliance back in service.

- **Blower Motor:** Annual oiling of the blower motor with SAE 20 oil will extend bearing life significantly. Ensure that the squirrel cage in the blower is kept clean. If dirt becomes a problem, installation of outside air intake ducts for combustion is recommended.

Check lubrication instructions on motor. If oiling is required, add three or four drop of SAE 20 electric motor oil.

- After three years or 25,000 hour (for light-duty operation).
- Annually after three years or 8,000 hours (for medium-duty operation).
- Annually after one year or 1,500 hours (for heavy-duty operation).

NOTICE

Never over-oil the motor or premature failure may occur.

Troubleshooting Flowchart

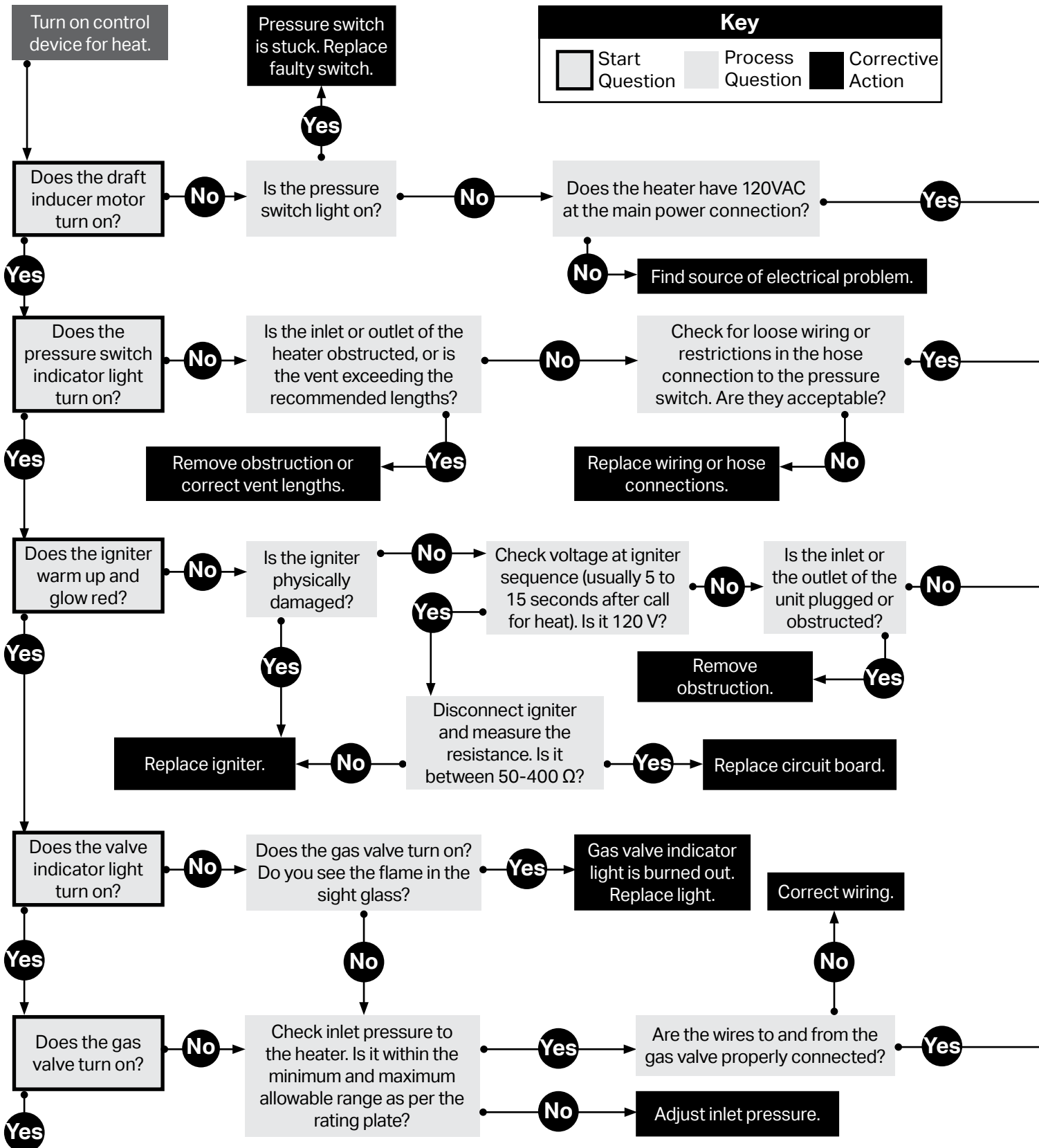

Continued on page 46

Continued from page 44

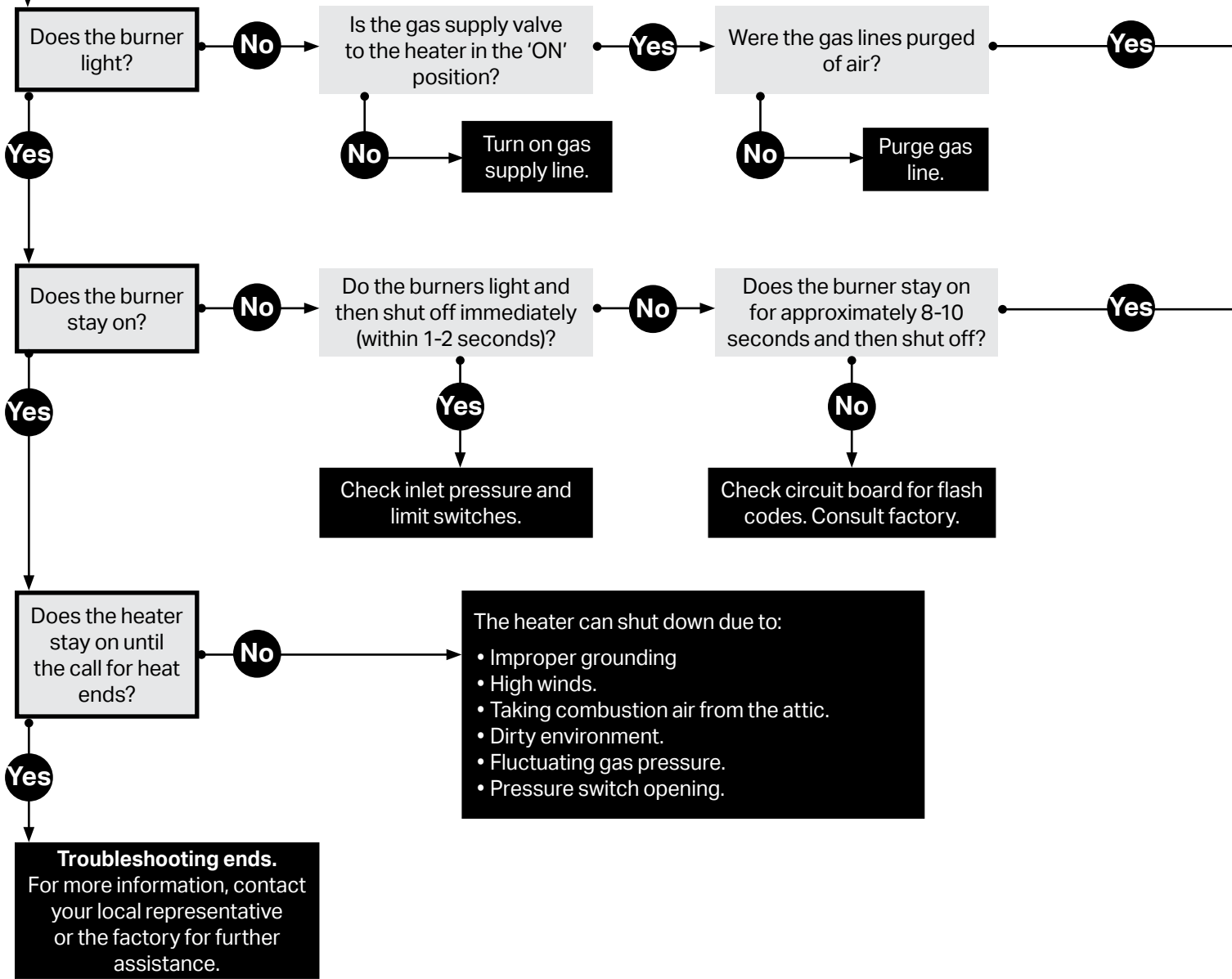

Continued from page 45

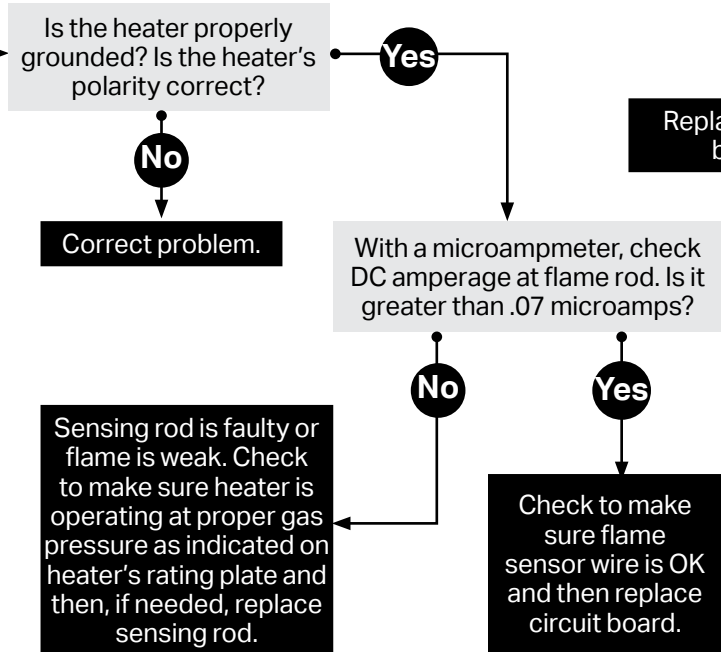
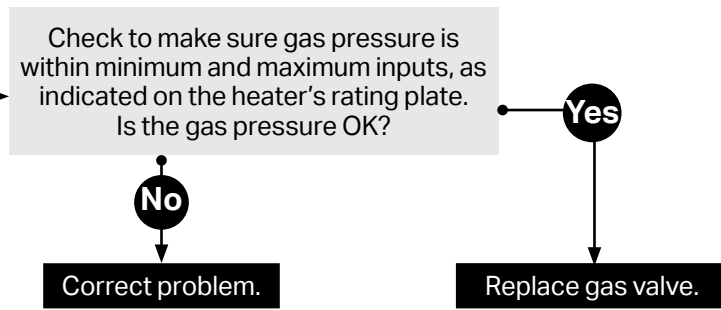

The heater is equipped with two safety pressure switches. The burner switch is a normally open switch and the exhaust switch is a normally closed switch. **Temporarily** place jumpers across the terminals of the exhaust switch (reinstall control box cover). Does the igniter glow red?

NOTE: If normal operation does not continue after bypassing the exhaust switch, consult factory to troubleshoot the burner switch prior to continuing.

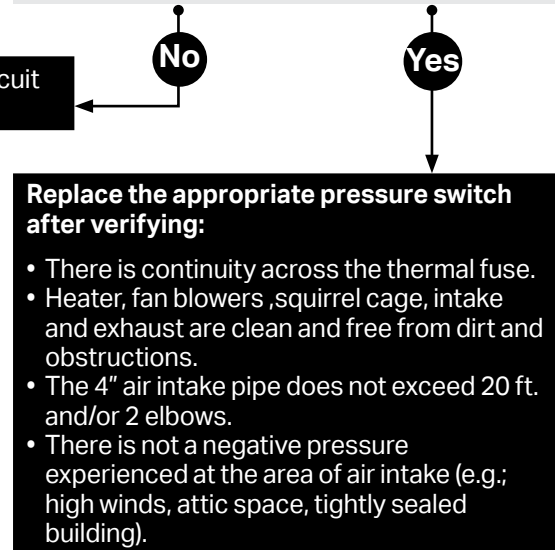

If heater does not go into high fire mode:

NOTE: To confirm that the heater is not in high fire mode, check manifold pressure. If manifold pressure is 3.3" to 3.5" for natural gas or 9" to 10" for propane, the light is faulty and should be replaced.

When the heater is in low fire mode, manifold pressure is approximately 2.0" to 2.5" for natural gas or 5.0" to 6.5" for propane. If this is the case, the following troubleshooting steps should be followed:

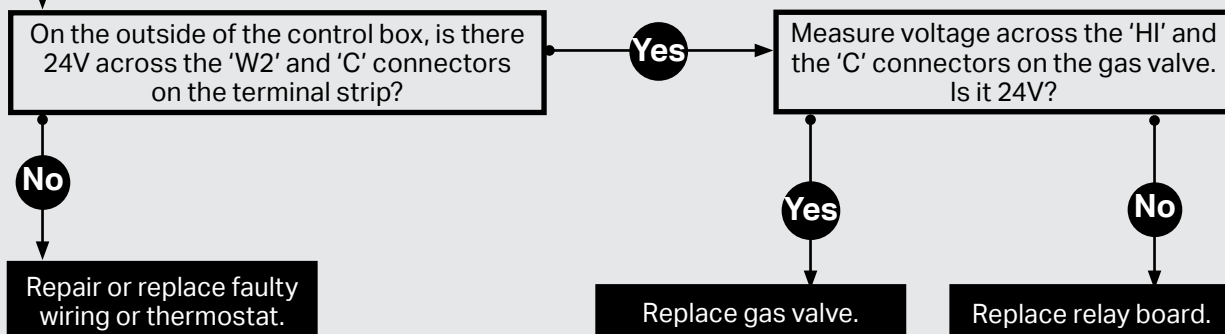

Chart 5.1 • DST Series Parts List

Part No.	Description	Part No.	Description
TP-41	1/4" - 20 Keps Nut	TP-7010	Bracket - Exhaust
TP-50A	Glo-Bar Igniter	TP-7011	Egg Crate Assembly
TP-68B	Lg. Strain Relief Bushing	TP-7015	Fan Motor
TP-205	Glo-Bar Holder	TP-7016	Fan Capacitor
TP-206	Glo-Bar Holder Spring Clip	TP-7021	#8 x 1/2" SMS Stainless Steel
TP-222	Flame Rod	TP-7022	3/8" Split Washer
TP-260J	N.C. Pressure Switch (60 MBH)	TP-7023	#8 x 1/4" SLTD HW "B" Black Finish Screw
TP-260L	N.C. Pressure Switch (80 MBH)	TP-7024	3/8" -16 x 3/4" Hex Cap Grade 5
TP-264K	N.O. Pressure Switch (60 MBH)	TP-7026A	Aluminized Radiant Tube - Exhaust
TP-264M	N.O. Pressure Switch (80 MBH)	TP-7026B	Titan-Alum Radiant Combustion Tube
TP-332	Divider Grommet	TP-7035	Wire Harness
TP-826	40 VA Transformer	TP-7040	Gas Valve Assembly - Natural
TP-828	Amber Indicator Light	TP-7041	Gas Valve Assembly - Propane
TP-851C	Circuit Board	TP-7042	Service Port Plug
TP-933	6' Black 120 VAC Power Cord	TP-7048	Flare Fitting
TP-944	6' Yellow 120 VAC Control Cord	TP-7044	Gas Manifold
TP-1325	Relay	TP-7045	Panel Thumb Screw
TP-3014	Air Collar (Specify Size)	TP-7046	Hanging Bolt Kit
TP-3186	High Temperature Grommet	TP-7069	Vent Breather
TP-7001	Exterior Chassis	TP-7070	Burner (Orange)
TP-7002	Air Box	TP-7075	Cast Elbow
TP-7003	Module End Panel	TP-7078	Tube Support
TP-7004	End Panel	TP-7079	Tube Brace
TP-7005	Hanging Bracket	TP-7080	Burner Tube, Flange, Ignition Plate, Gasket, & Sight Glass Kit
TP-7008	Component Panel	TP-7082	Aluminized Radiant Tube - Middle
TP-7009	Bracket - Exhaust		

Visit our online parts library at www.store.reverberray.com for further parts related information.

Limited Warranty Terms and Conditions

Three-Year Limited Warranty: The heaters covered in this manual are warranted by Detroit Radiant Products Company to the original user against defects in workmanship or materials under normal use for three years after date of purchase. Any part which is determined to be defective in material or workmanship and returned to an authorized service location, as Detroit Radiant Products Company designates, shipping costs prepaid, will be, as the exclusive remedy, repaired or replaced at Detroit Radiant Products Company's option. For limited warranty claim procedures, see PROMPT DISPOSITION below. This limited warranty gives purchasers specific legal rights which vary from jurisdiction to jurisdiction.

Additional Limited Warranty: In addition to the above mentioned three-year warranty, Detroit Radiant Products Company warrants the original purchaser an additional extension on the heat exchangers and burners. This extension excludes electrical/purchased components.

General Conditions: The Company will not be responsible for labor charges for the analysis of a defective condition of the heater or for the installation of replacement parts. The warranties provided herein will not apply if the input of the heater exceeds the rated input at time of manufacturing or if the heater in the judgment of the Company has been subjected to misuse, excessive dust, improper conversion, negligence, accident, corrosive atmospheres, excessive thermal shock, excessive vibration, physical damage to the heater, alterations by unauthorized service personnel, operation contrary to the Company's instructions or if the serial number has been altered, defaced, or removed. The Company shall not be liable for any default or delay in the performance of these warranties caused by contingency beyond its control, including war, government restriction or restraints, strikes, fire, flood, short or reduced supply of raw materials, or parts.

Limitation of Liability: To the extent allowable under applicable law, Detroit Radiant Products Company's liability for consequential and incidental damages is expressly disclaimed. Detroit Radiant Products Company's liability in all events is limited to and shall not exceed the purchase price paid.

Warranty Disclaimer: Detroit Radiant Products Company has made a diligent effort to provide product information and illustrate the products in this literature accurately; however, such information and illustrations are for the sole purpose of identification, and do not express or imply a warranty that the products are merchantable, or fit for a particular purpose, or that the products will necessarily conform to the illustrations or descriptions. Except as provided below, no warranty or affirmation of fact, expressed or implied, other than as stated in the "LIMITED WARRANTY" above is made or authorized by Detroit Radiant Products Company.

Product Suitability: Many jurisdictions have codes and regulations governing sales, construction, installation, and/or use of products for certain purposes, which may vary from those in neighboring areas. While Detroit Radiant Products Company attempts to assure that its products comply with as many codes, it cannot guarantee compliance, and cannot be responsible for how the product is installed or used. Before purchase and use of a product, review the product applications, and all applicable national and local codes and regulations, and be sure that the product, installation, and use will comply with them. Certain aspects of disclaimers are not applicable to consumer products:

e.g., (a) some jurisdictions do not allow the exclusion or limitation of incidental or consequential damages, so the above limitation or exclusion may not apply to you; (b) also, some jurisdictions do not allow a limitation on how long an implied warranty lasts, consequently the above limitation may not apply to you; and (c) by law, during the period of this limited warranty, any implied warranties of implied merchantability or fitness for a particular purpose applicable to consumer products purchased by consumers, may not be excluded or otherwise disclaimed.

Prompt Disposition: Detroit Radiant Products Company will make a good faith effort for prompt correction or other adjustment with respect to any product which proves to be defective within limited warranty. For any product believed to be defective within limited warranty, first write or call dealer from whom the product was purchased. Dealer will give additional directions. If unable to resolve satisfactorily, write to Detroit Radiant Products Company at 21400 Hoover Road, Warren, Michigan 48089, listing dealer's name, address, date and number of dealer's invoice, and describe the nature of the defect. Title and risk of loss pass to buyer on delivery to common carrier. If product was damaged in transit to you, file claim with carrier.

Kit Contents

Chart 5.3 • Kit Contents for DST Series

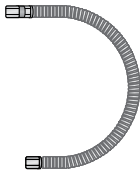
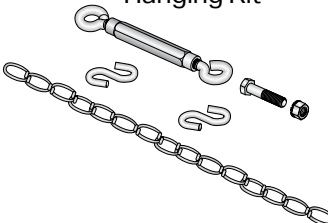
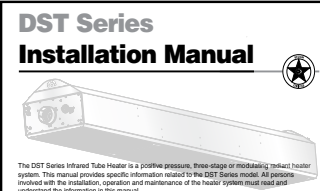
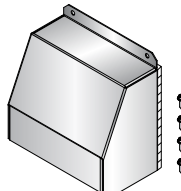
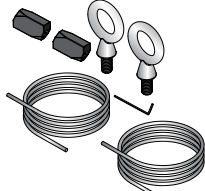
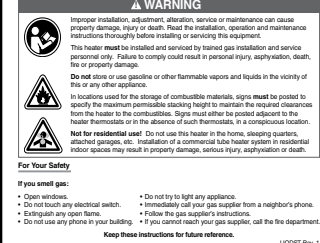
DST Series Kit Contents		
<p>FC-24 1/2" x 24" 304 Stainless Steel Flexible Gas Connector</p> 	<p>DST-HANG Hanging Kit</p> 	<p>LIODST DST Series Installation, Operation and Maintenance Manual</p> 
<p>DST-EXH Exhaust Kit</p> 	<p>DST-GRIP Gripple Kit for Standard Mounting</p> 	<p>DST Series Installation Manual</p> 
Part No.	Description	Quantity
FC-24	1/2" x 24" 304 Stainless Steel Flexible Gas Connector	
DST-EXH	Exhaust Hood with Birdscreen (1), #8 x 1/2" Stainless Sheet Metal Screw (4)	
DST-GRIP	#3 10' Gripple Cable (2), #3 Joiner & Tensioner (2), Release Key (1), 3/8"-16 Zinc-Plated Eyebolt (2)	
DST-HANG	Stainless Steel Bolts (4), Stainless Steel Keps Nuts (4), Stainless Steel S-Hooks (8), Zinc-Plated Turnbuckle (4), 1/0 Stainless Steel Bulldog Chain (4)	
Filled By:		

Approvals

- ANSI Z83.20-2016 and CSA 2.34-2016 (60,000 BTU/h Models Only)
- ANSI Z86.26-2014 and CSA 2.37-2014 (All Models)
- Indoor Approval (60,000 BTU/h Models Only)
- Residentially Outdoor Certified to CSA No. 7-89
- Commercial Approval

Limited Warranty

- 3 year - Burner box components
- 5 years - Combustion and radiant tubes
- 10 years - Stainless steel burner
- See page 50 for terms and conditions.



© 2018 Detroit Radiant Products Co.
 21400 Hoover Road • Warren, MI 48089
 Phone: (586) 756-0950 Fax: (586) 756-2626
 www.detroitradiant.com • sales@drp-co.com

