



DX3L SERIES TUBE HEATERS

SUBMITTAL DATA – SINGLE-STAGE LOW INTENSITY GAS-FIRED INFRARED TUBE HEATERS & ACCESSORIES

SUBMITTED BY: _____ DATE: _____

JOB TITLE: _____ CONTRACTOR: _____

ADDRESS: _____ PHONE #: _____

CITY: _____ ADDRESS: _____

STATE: _____ ZIP: _____ CITY: _____

STATE: _____ ZIP: _____

ENGINEER: _____

LOCAL REPRESENTATIVE: _____

NOTES: _____

QTY.	MODEL #	TAG	INDICATE GAS TYPE	BTU/h INPUT	STRAIGHT LENGTH	U-TUBE LENGTH	STANDARD WEIGHT	TYP. OR RCMD. MOUNTING HEIGHTS ¹
	DX3L-20-50		N or P	50,000	21'-9"	13'-1"	120 lbs.	9' to 14'
	DX3L-20-60		N or P	60,000	21'-9"	13'-1"	120 lbs.	10' to 15'
	DX3L-20-75		N or P	75,000	21'-9"	13'-1"	120 lbs.	11' to 18'
	DX3L-30-50		N or P	50,000	31'-5"	17'-9" ²	160 lbs.	10' to 15'
	DX3L-30-60		N or P	60,000	31'-5"	17'-9" ²	160 lbs.	11' to 18'
	DX3L-30-75		N or P	75,000	31'-5"	17'-9" ²	160 lbs.	12' to 20'
	DX3L-30-100		N or P	100,000	31'-5"	17'-9" ²	160 lbs.	13' to 23'
	DX3L-30-125		N or P	125,000	31'-5"	17'-9" ²	160 lbs.	14' to 25'
	DX3L-40-50		N or P	50,000	41'-1"	22'-9"	190 lbs.	11' to 18'
	DX3L-40-60		N or P	60,000	41'-1"	22'-9"	190 lbs.	11' to 18'
	DX3L-40-75		N or P	75,000	41'-1"	22'-9"	190 lbs.	12' to 20'
	DX3L-40-100		N or P	100,000	41'-1"	22'-9"	190 lbs.	13' to 23'
	DX3L-40-125		N or P	125,000	41'-1"	22'-9"	190 lbs.	14' to 25'
	DX3L-40-150		N or P	150,000	41'-1"	22'-9"	190 lbs.	15' to 27'
	DX3L-40-175		N or P	175,000	41'-1"	22'-9"	190 lbs.	16' to 30'
	DX3L-50-100		N or P	100,000	50'-9"	27'-5" ²	235 lbs.	15' to 27'
	DX3L-50-125		N or P	125,000	50'-9"	27'-5" ²	235 lbs.	15' to 27'
	DX3L-50-150		N or P	150,000	50'-9"	27'-5" ²	235 lbs.	16' to 30'
	DX3L-50-175		N or P	175,000	50'-9"	27'-5" ²	235 lbs.	17' to 35'
	DX3L-50-200		N or P	200,000	50'-9"	27'-5" ²	235 lbs.	18' to 40'
	DX3L-60-125		N or P	125,000	60'-5"	32'-5"	265 lbs.	16' to 30'
	DX3L-60-150		N or P	150,000	60'-5"	32'-5"	265 lbs.	17' to 35'
	DX3L-60-175		N or P	175,000	60'-5"	32'-5"	265 lbs.	17' to 35'
	DX3L-60-200		N or P	200,000	60'-5"	32'-5"	265 lbs.	18' to 40'
	DX3L-70-175		N or P	175,000	70'-1"	37'-3" ²	300 lbs.	19' to 42'
	DX3L-70-200		N or P	200,000	70'-1"	37'-3" ²	300 lbs.	19' to 42'
	DX3L-80-200		N or P	200,000	79'-9"	42'-1"	330 lbs.	20' to 45'

¹ Typical or recommended mounting heights are provided as a guideline. Actual conditions may dictate variations from this data.

² Model requires 5EA-SUB accessory package when installing heater in a U-shaped configuration.

DETROIT RADIANT PRODUCTS CO.



21400 Hoover Rd.
Warren, MI 48089-3162

Phone: (586) 756-0950
Toll Free: (800) 222-1100
Fax: (586) 756-2626
Email: sales@drp-co.com
Website: www.reverberray.com

VISIT OUR WEBSITE FOR:

- Product Specs
- Parts Support
- Dealer Locator
- Applications
- CAD/Revit Library
- Design Guidelines
- Theory of Infrared
- and More!

DX3L SPECIFICATIONS

APPROVALS

- CSA Design Certified
- Commercial/Industrial Approval
- Indoor approval
- Outdoor approval with OD-Kit

BURNER CONTROL BOX

- Sight glass for burner inspection
- Totally enclosed components
- Serviceable while in operation
- Coated enameled steel
- Operational indicator lights

GAS CONNECTION

- 7/8 in. flare-M FPT connection to 1/2 in. x 24 in. (304) SS flex connector provided.

GAS SUPPLY (Inches W.C.)

- Manifold pressure: Nat 3.5; Prop 10.0
- Min. inlet pressure: Nat 5.0; Prop 11.0
- Max. inlet pressure: Nat 14.0; Prop 14.0

POWER SUPPLY

- 120 VAC, 60 Hz GRD, 1 Ph., 3-wire
- 60 in. grounded power cord
- Ignition current - 4.8 amps
- Running current - 1.1 amps
- 60 in. grounded power cord

CONTROLS

- Air proving safety switch
- Silicon carbide hot surface ignition
- Pre- & post-purge controls
- Flame rod sensing
- 24V thermostatic control voltage
- Self-diagnostic LED

REFLECTOR

- Highly polished aluminum
- Two end caps included
- Reflector tension springs
- Continuous overlap design
- One reflector center support per reflector

COMBUSTION & RADIANT TUBES

- 16ga. 4" O.D. aluminized coated steel radiant emitter tubes
- Titanium coated combustion chamber (150-200 MBH models)
- All tubes coated with high temperature, corrosion resistant black coating, .95 emissivity
- Slip-fit swaged tube connection.
- Turbulator baffle

COMBUSTION AIR INLET & VENTING

- Preset 4 in. combustion air inlet collar
- Sidewall or roof venting

LIMITED WARRANTY

- 3 year - Burner box components
- 5 years - Combustion and radiant tubes
- 10 years - Burner

DX3L CLEARANCES TO COMBUSTIBLES (IN INCHES)

MODEL NO.	MOUNTING ANGLE ³	SIDE			
		FRONT	BEHIND	TOP	BELOW
DX3L (20, 30, 40) - 50, 60 [N,P]	0°	9	9	6	47
	45°	39	8	10	47
w/1 side shield	0°	29	8	6	47
w/2 side shields	0°	9	9	6	47
20 ft. from burner	0°	7	7	6	30
DX3L (20, 30, 40) - 75 [N,P]	0°	9	9	6	60
	45°	39	8	10	60
w/1 side shield	0°	29	8	6	60
w/2 side shields	0°	9	9	6	60
20 ft. from burner	0°	7	7	6	30
DX3L (30, 40, 50) - 100 [N,P]	0°	14	14	6	66
	45°	39	8	10	66
w/1 side shield	0°	29	8	6	66
w/2 side shields	0°	16	16	6	66
20 ft. from burner	0°	7	7	6	30
DX3L (30,40, 50, 60) - 125 [N,P]	0°	20	20	6	76
	45°	58	8	10	76
w/1 side shield	0°	42	8	6	76
w/2 side shields	0°	20	20	6	76
20 ft. from burner	0°	7	7	6	30
DX3L (40, 50, 60) - 150 [N,P]	0°	24	24	6	81
	45°	58	8	10	81
w/1 side shield	0°	42	8	6	81
w/2 side shields	0°	23	23	6	81
20 ft. from burner	0°	11	11	6	44
DX3L (40,50, 60, 70) - 175 [N,P]	0°	34	34	6	92
	45°	63	8	10	92
w/1 side shield	0°	50	8	6	92
w/2 side shields	0°	30	30	6	92
20 ft. from burner	0°	11	11	6	44
DX3L (50, 60, 70, 80) - 200 [N,P]	0°	41	41	6	94
	45°	63	8	10	94
w/1 side shield	0°	54	8	6	94
w/2 side shields	0°	30	30	6	94
20 ft. from burner	0°	11	11	6	44

³ Heaters mounted on an angle between 0° and 45° must maintain clearances posted for 0° or 45°; whichever is greater.

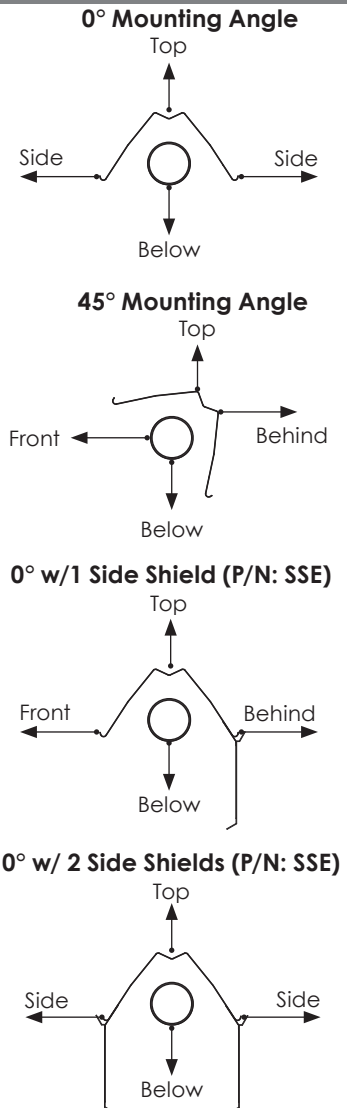

Read and understand the installation, operation and maintenance manual prior to installing or servicing this unit.

In locations used for the storage of combustible materials, signs must be posted adjacent to the heater's thermostat specifying stacking heights.

DX3L SERIES FIELD DATA

Burner Control Box with U-Bend - End View

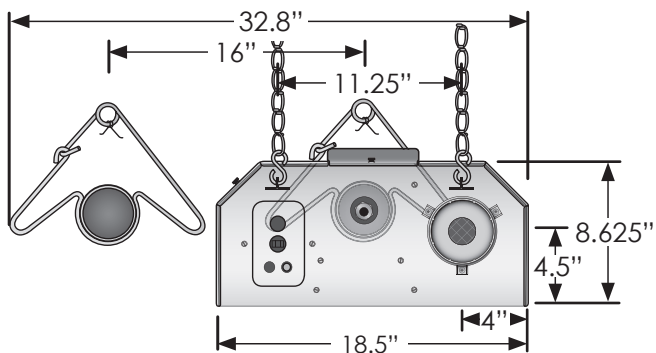

Side View

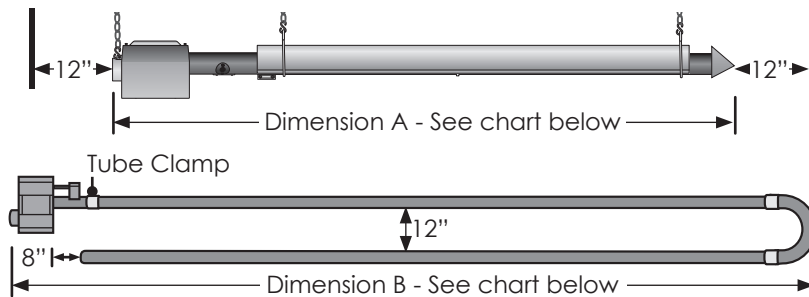
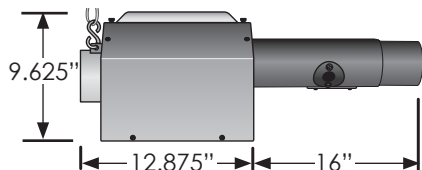

MODEL NUMBER	DIMENSION A STRAIGHT	DIMENSION B U-TUBE
DX3L-20	21' - 9"	13' - 1"
DX3L-30	31' - 5"	17' - 9" ⁴
DX3L-40	41' - 1"	22' - 9"
DX3L-50	50' - 9"	27' - 5" ⁴
DX3L-60	60' - 5"	32' - 5"
DX3L-70	70' - 1"	37' - 3" ⁴
DX3L-80	79' - 9"	42' - 1"

⁴with 5EA-SUB

OPTIONAL ACCESSORIES

QTY.	PART #	DESCRIPTION	NOTES
	10EA	10'x4" Tube & Reflector Extension	Optional 10 ft. extension package. Maximum of one per unit.
	4-DSK	4" Sidewall Vent Kit	Required for all single sidewall vents. No roof venting.
	6-DSK	6" Sidewall Vent Kit	Required for all common sidewall vents. No roof venting.
	BK	Angle Mounting Bracket 15-30-45 Deg.	Rotates reflector to preset mounting angles.
	E6	90 Degree, 4" Radiant Elbow	Used for making a L-shaped heater. Maximum of two per unit.
	PG	Protective Guard	Protects heat exchanger from contact or objects. Each 5 ft. in length.
	PLQ	Warning Plaque	Hung below heater, restates the clearance to combustible warning.
	REP	Reflector & Elbow Package	Reflector and accessories used to configure heater in a 'L' shape.
	RTVP-4	4" Rooftop Vent Package	Used to single vent vertically through the roof.
	RTVP-6	6" Rooftop Vent Package	Used to common vent vertically through the roof.
	RUP	Reflector & 'U' Bend Package	Reflector and accessories used to configure heater in a 'U' shape.
	SMB	Single Mount Bracket	Provides units with 'U' bend uniform mounting points. One per 10 ft.
	SSE	Side Shield Extension	Reflector side guard used to lower side clearances. Each 5 ft. in length.
	TF1B	180 Degree, 4" Radiant 'U' Bend	Used for making a U-shaped heater. Maximum of one per unit.
	THCS	Tube Heater Chain Set	5 ft. chain set with two S-hooks used for hanging heater.
	TR60	5'x4" Tube & Reflector Extension	Optional 5 ft. extension package. Maximum of two per unit.
	WIV-4	4" Combustion Air Intake - Sidewall Cap	Used to duct fresh (cold) air 0-30 ft. to a heater. Sidewall only.
	WVE-GALV	4" Unvented Exhaust Termination Cap	Required on all units when operating unvented.
	Y	4"x6"x4" Aluminized Common Vent Fitting	Used for joining two heaters on one vent. Same thermostat required.
	YSM	4"x6"x4" Galvanized Common Vent Fitting	Used for joining two heaters on one vent. Same thermostat required.

OPTIONAL UPGRADES

- CNG-AO** Upgrades tube heater to be CNG designated. Includes one liner tube to be installed in each combustion tube. **For 30' and 40' models, 60MBH and under only.**
- SILSEAL** Protects internal burner box components against contaminants.
- 5EA-SUB** Substitute one 10 ft. radiant tube and reflector for two 5 ft. pieces. This is ideal for making U-shaped heaters from 30 ft. and 50 ft. models. Maximum of one per heater.
- OD-KIT** For use when applying heaters outdoors.

STAINLESS STEEL UPGRADES

- SSRAO** 10 ft. Reflector Section.
- SSTAO** 10 ft. Tube Section (75-200 MBH only). Not available on 30-125, 40-175, 50-200 models.
- SSTRAO** Tubes & Reflectors (75-200 MBH only). Not available on 30-125, 40-175, 50-200 models.
- SSB-##** Mounting Brackets (## = heater length).
- SSC-##** Tube Clamps (## = heater length).

NOTE: Refer to the Tube Heater Accessory List (LPKTH) for detailed specifications and limitations on any of the above options.

DX3L WRITTEN SPECIFICATIONS

PRODUCTS

1. TUBULAR INFRARED HEATERS

- A. Basis-of-design product: Subject to compliance with requirements, provide Detroit Radiant Products Company; **Re-Verber-Ray DX3L Series.**
- B. Fuel type: Burner shall be designed for [natural] [propane] gas having characteristics same as those of gas available at project site.
- C. Combustion chamber: Shall be 4 inch O.D. 16ga. Titanium stabilized aluminized steel (150-200 MBH to allow for the operating temperature to exceed the 1030°F as set forth in the ANSI Z83.20 Standard) or aluminized steel (below 150 MBH), finished with a high emissivity rated, corrosion resistant, black coating with an emissivity level documented at .92 or higher. (A 409 grade stainless steel chamber shall be used when specified for harsher environments).
- D. Emitter tube: Shall be 4 inch O.D. 16ga. aluminized steel finished with a high emissivity rated, corrosion resistant, black coating with an emissivity level documented at .92 or higher. (A 304 grade stainless steel emitter tube shall be used when specified for harsher environments).
- E. Burner type: Unit shall be a positive pressure power burner with a combustion fan upstream of the burner and exhaust gases for component longevity, maximum combustion efficiency, and energy transfer. Negative pressure (pull through) type appliances will not be allowed.
- F. Fan enclosure: Combustion fan shall be totally housed inside burner control box and not exposed. Appliances with exposed combustion/exhauster fans shall not be permitted.
- G. Burner: Stainless-steel venturi burner. The flame anchoring screen shall have a minimum temperature rating equivalent to 430 grade stainless steel. Non stainless steel burners shall not be permitted.
- H. Tube connections: The heater's combustion chamber and radiant emitter tube shall incorporate a 4 inch slip-fit, interlocking connection in which the upstream tube slides into the next tube and is held by a bolted clamp. A butted tube connection system shall not be permitted.
- I. Ignition system: Hot surface silicon carbide capable of temperatures achieving 2400°F. Igniter shall be readily accessible and serviceable without the use of tools. Spark ignition systems shall not be permitted.
- J. Reflectors: Shall be .025 polished aluminum with a multi-faceted design which includes reflector end caps. Reflector shall have a polished bright finish with clear visual reflection ability. (A sample will be required at time of submittal). Reflector shall have a minimum of 7 sheet metal bends in its fabrication to optimize downward radiation. Reflectors shall be rotatable from 0 to 45 degrees when required. The heater's reflector hanging system shall be designed to permit expansion while minimizing noise and/or rattles. (A 304 grade stainless steel reflector material shall be used when specified for harsher environments).
- K. Control box: Heater's exterior control chassis shall be constructed of corrosion resistant enameled steel.
 1. The heater's top cover shall be constructed of ABS plastic material.
 2. Air intake: An air intake collar shall be supplied as part of the burner control assembly to accept a 4 inch O.D. supply duct.
 3. The heater's control compartment shall be accessible without the use of tools and serviceable while heater is operating.
 4. Outdoor modifications are required for any application that will be placed in a space defined as outdoors. The rating label shall bear the outdoor certification approval.
- L. Heaters shall be equipped with a sight glass allowing a visual inspection of igniter and burner operation from the floor. Sight glass visible only at appliance level shall not be permitted.
- M. The heaters shall utilize a downstream turbulator baffle for maximum heat transfer.
- N. Heater shall be supplied with a stainless steel flexible gas connector.
- O. Burner Safety Controls:
 1. Heater controls shall include a safety differential pressure switch to monitor combustion air flow, as to provide complete burner shutdown due to insufficient combustion air or flue blockage.
 2. The heater shall incorporate a self-diagnostic ignition module, and recycle the heater after an inadvertent shutdown.
 3. The heater's control system shall be designed to shut off the gas flow to the main burner in the event either a gas supply or power supply interruption occurs.
 4. The heater's blower motor shall be thermally protected and the motor's impeller shall be balanced.
 5. Heater control assembly shall include two indicator lights. One indicator shall validate air flow. One indicator light shall indicate valve operation.
 6. The heater's air flow control system shall provide a 45 second pre-purge prior to initiating burner operation and a 90 second post-purge upon completion, effectively removing all products of combustion from heat exchanger and/or radiant tubes.
 7. No condensation shall form as a result of combustion in the combustion chamber or radiant tubes while at operating temperatures.
 8. Thermostat control shall be single-stage operating on 24 volts.
- P. Venting: Shall be per manufacturer approval and specifications.
- Q. Thermostat: Devices and wiring are specified in Division 23 Section "Instrumentation and Control for HVAC."
 1. Thermostat: single-stage, digital programmable wall-mounting type with 50 to 90 deg F (10 to 32 deg C) operating range.